

# ***GENERAL PURPOSE ENGINE***

**GX25**

**PARTS CATALOGUE**

**2**



GX25

---

FOREWORD INDEX

**1**

---

ENGINE GROUP

**2**

---

PART NUMBER INDEX

**3**

---

PART NAME INDEX

**4**

---



**Instruction for use of parts catalogue**

- **This parts catalogue was prepared based on the latest information available as of January 22, 2007.**
- See the parts catalogue news for any revision that is made after January 22, 2007.
- **Always specify the part number when ordering a part.**
- Check the model, type, serial numbers, color, maker, and the size as needed before ordering a part.
- Note that the illustrations (part drawings) can differ from the actual parts in shape. They are given just to help you to refer to the parts.
- **When modifications or additions to this parts catalogue are made, a revised edition will be issued at an appropriate time, with successively progressing revision numbers on the cover. We recommend obtaining such revisions in order to keep your parts catalogue up-to-date at all times. To check whether a parts catalogue revision has been issued, please contact your Honda distributor.**

Initial version issue date **August 20, 2002**  
**Honda Motor Co., Ltd.**

**CONTENTS**

	Page	Address No.	
● Instruction for use of parts catalogue .....	1	B 1	<b>1</b>
● How to refer to the part information .....	2	B 2	
● Part catalogue structure .....	3	B 3	
● When the parts were revised .....	4	B 4	
● Abbreviations used in the parts catalogue .....	4	B 4	
● How to check the part block and serial numbers .....	5	B 5	
● Models, parts catalogue codes and applicable serial numbers .....	6	B 6	
● Features of each type .....	8	B 8	
● Fuel hose, general purpose hoses and vinyl hose .....	9	B 9	
● FLAT RATE SERVICE TIME .....	10	B10	
● Illustrated index .....	15	B15	
● ENGINE GROUP .....	17	C 1	<b>2</b>
● PART NO. INDEX .....	43	E 1	<b>3</b>
● PART NAME INDEX .....	45	F 1	<b>4</b>



How to refer to the part information

A Reference with "Illustrated index"

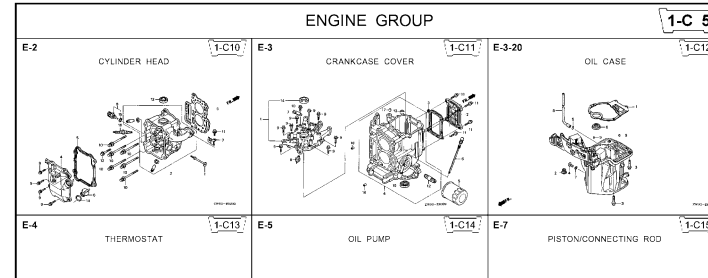

B Reference with "Part number index"

PART NO. INDEX					
Part Number	Address	Page	Rel.	Part Number	Address Page
06000				15212-ZW9-000	1-C14 3C
06316-ZW9-000	1-69	88	1	15220-ZW9-003	1-C14 3C
11000				15332-ZW9-000	1-E8 55
11300-ZW9-405	1-C11	27	1	15332-ZW9-A30	1-E11 5E
11300-ZW9-406	1-C11	27	1	15400-PFB-004	1-C11 27
11340-ZW9-000	1-C11	27	2	15422-ZW9-000	1-C14 3C
11342-ZW9-000	1-C11	27	3	15473-881-000	1-C14 3C
11381-ZW9-003	1-C12	28	1	15474-ZW9-000	1-C14 3C
				15611-921-000	1-C10 2E
				15655-ZW9-000	1-C11 27
				16000	
12000				16010-ZV4-005	1-D4 3E
12000-ZW9-405ZA	1-C11	27	4	16011-ZV4-005	1-D4 3E
12155-ZV4-A00	1-C13	29	1	16013-ZW9-003	1-D4 3E
12166-ZW9-000	1-C10	26	1	16016-ZW9-003	1-D4 3E
12209-GB4-681	1-C16	32	1	16016-ZW9-721	1-D4 3E
12210-ZW9-405ZA	1-C10	26	2	16023-ZW9-003	1-D4 3E
12216-ZE2-300	1-E8	55	1	16024-ZV4-650	1-D4 3E
	1-E11	58	1	16028-ZV4-650	1-D4 3E

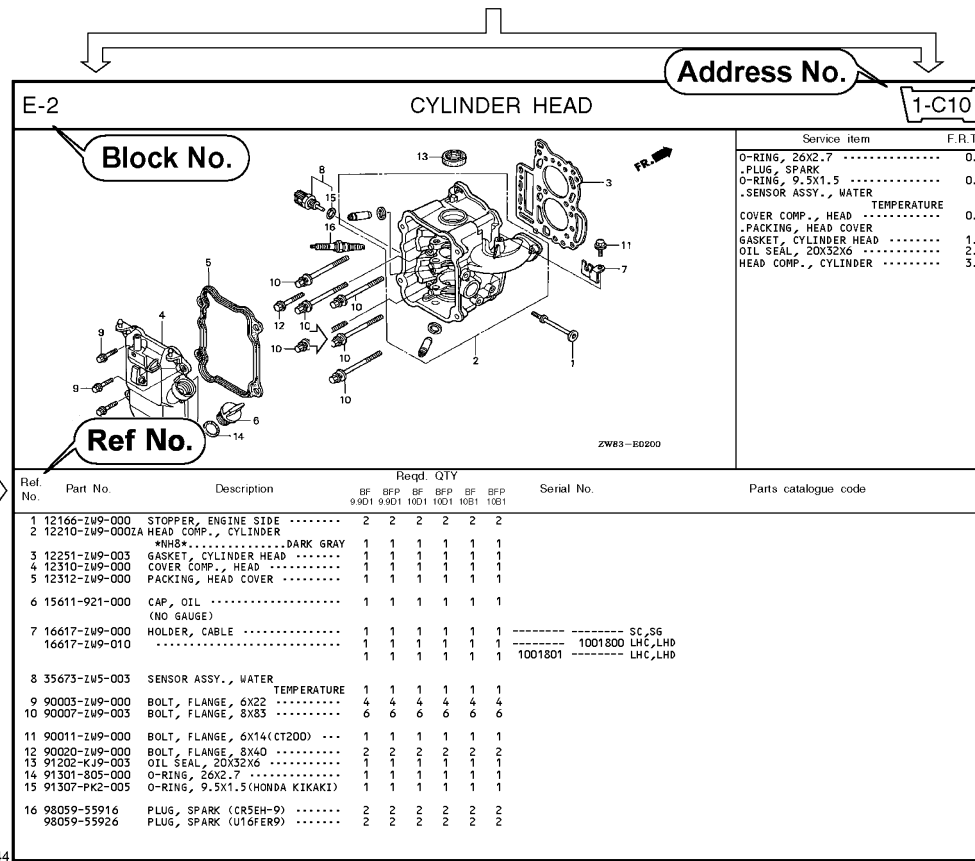

C Reference with "Part name index"

PART NAME INDEX					
Part name	Address	Page	Ref.		
[ A ]					
ABSORBER, FUEL	1-E15	62	5	BOLT,	
ARMATURE COMP.	1-D11	43	7	BOLT,	
ARM COMP., LINK JOINT	1-G6	85	18	BOLT,	
ARM COMP., SHIFT LINK	1-G6	85	14	BOLT,	
ARM COMP., TILT	1-F15	79	20		
ARM, FUEL PUMP ROCKER	1-C16	32	4		
ARM, REVERSE LOCK	1-F15	79	18		
ARM, SHIFT LINK	1-F11	74	7		
ARM, STOPPER	1-D1	33	12	BOLT,	
ARM, THROTTLE REMOTE	1-F11	74	6		
ARM, VALVE ROCKER	1-C16	32	3		
[ B ]					
BAG, TOOL, 160MM	1-G5	84	10		
BAND	1-G6	86	37		
BAND B1, WIRE	1-F6	69	1		
BAND, CORD	1-F3	67	18	BOLT,	
BAND, TUBE CLIP, 11MM	1-E15	63	20		
BAND, TUBE CLIP, 12.5MM	1-E15	63	19	BOLT,	

Page No.

2000.09.20 E

**Part catalogue structure**

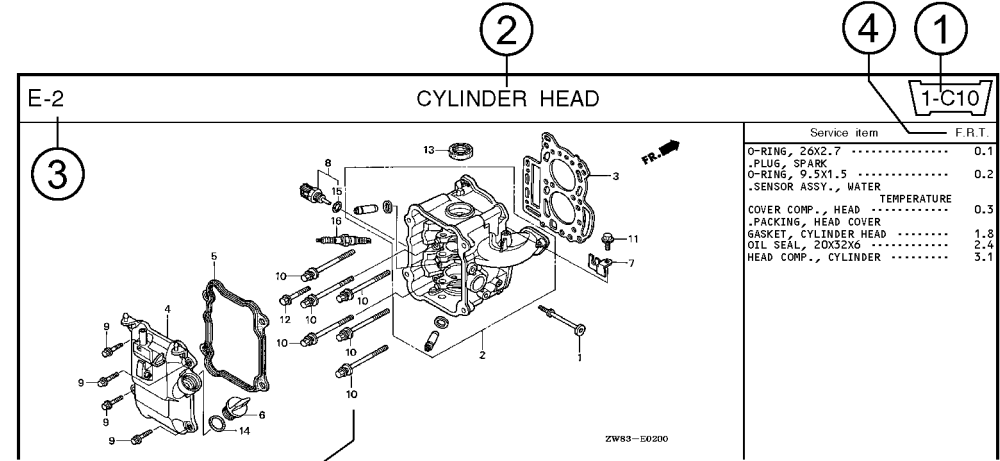

Ref. No.	Part No.	Description	Reqd. QTY						Serial No.	Parts catalogue code
			BF 9/901	BFP 9/901	BF 1001	BFP 1001	BF 1081	BFP 1081		
1	12166-zw9-000	STOPPER, ENGINE SIDE	2	2	2	2	2	2		
2	12210-zw9-000ZA	HEAD COMP., CYLINDER *NH8*	1	1	1	1	1	1		
3	12251-zw9-003	GASKET, CYLINDER HEAD	1	1	1	1	1	1		
4	12310-zw9-000	COVER COMP., HEAD	1	1	1	1	1	1		
5	12312-zw9-000	PACKING, HEAD COVER	1	1	1	1	1	1		
6	15611-921-000	CAP, OIL (NO GAUGE)	1	1	1	1	1	1		
7	16617-zw9-000	HOLDER, CABLE	1	1	1	1	1	1	SC,S6	
	16617-zw9-010		1	1	1	1	1	1	1001800 LHC,LHD	

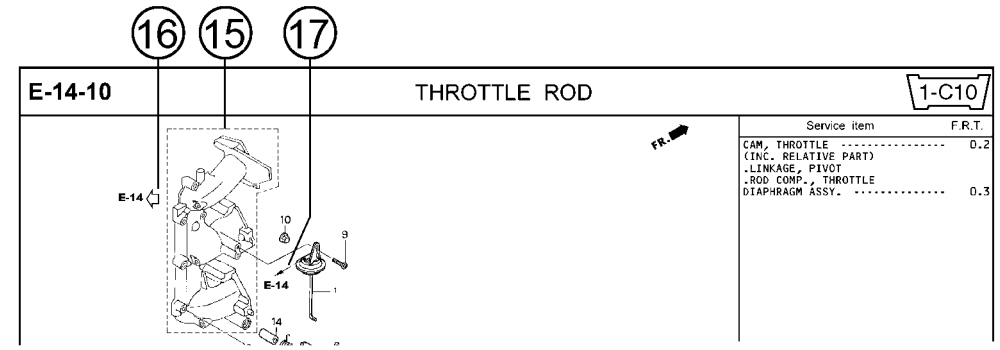

- ① **Address number**
  - Address No. is provided (in place of the page No.) to help you refer to the part with the part No. or part name.
- ② **Block title** ③ **Block number**
- ④ **Service item/Flat rate time**
- ⑤ **Reference number**
  - Title number marked with the parenthesis or parentheses indicates that it continues from the previous page.
- ⑥ **Part number** ⑦ **Honda color code**
- ⑧ **Description**
- ⑨ **Assemblies**
  - Sections framed with broken lines in the exploded view drawings are available as complete assemblies. (Their individual parts can also be obtained.)
- ⑩ **Color description**
- ⑪ **Note**
  - Notes are shown with the parentheses in the part name column.
- ⑫ **Required quantity**
  - Required QTY shown in the parenthesis or parentheses indicates the optional part.
  - Required QTY marked with "N" Indicates the optional part that should be selected as needed.
  - Required QTY indicates the number of the part used in the block.
- ⑬ **Serial number**
- ⑭ **Type**
  - When the type column is blank, it indicates that the part is applicable to all types.
  - As the type of the actual unit may differ from the "parts catalogue, type" please refer to "Models, types and applicable serial numbers" for confirmation.
- ⑮ **[Dotted box]**
  - Parts enclosed within a dotted line [ ] are covered in a different block.
- ⑯ **[Hollow arrow]**
  - A hollow arrow [ ] indicates the block No. for the parts enclosed within a dotted line [ ] .
- ⑰ **[Solid arrow]**
  - A solid arrow [ ] indicates the block No. the part in question is connected to.

**When the parts were revised**

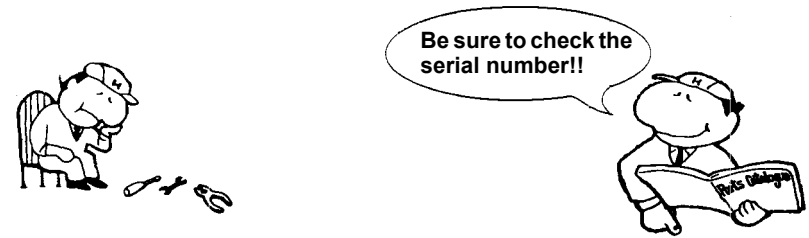

Ref. No.	Part No.	Description	Reqd. QTY						Serial No.
			BF 99D1	BFP 9.9D1	BF 10D1	BFP 10D1	BF 10B1	BFP 10B1	
1	12166-ZW9-000	STOPPER, ENGINE SIDE .....	2	2	2	2	2	2	
2	12210-ZW9-000ZA	HEAD COMP., CYLINDER *NH8*.....DARK GRAY	1	1	1	1	1	1	
3	12251-ZW9-003	GASKET, CYLINDER HEAD .....	1	1	1	1	1	1	
4	12310-ZW9-000	COVER COMP., HEAD .....	1	1	1	1	1	1	
5	12312-ZW9-000	PACKING, HEAD COVER .....	1	1	1	1	1	1	
6	15611-921-000	CAP, OIL (NO GAUGE) .....	1	1	1	1	1	1	
7	16617-ZW9-000	HOLDER, CABLE (###).....	1	1	1	1	1	1	
	16617-ZW9-010	.....	1	1	1	1	1	1	

The number has been used from the initial model without revision. When shown at the left side, it is applicable to the models of No.1001801 and the subsequent numbers. When shown at the right side, it is applicable to the models up to No.1001800.

• The parts listed with "###" at the end of the parts name have limited supply period (parts not for sale).

**Abbreviations used in the parts catalogue**

• The following abbreviations are used in the parts name column.

- A ..... Ampere
- A.C. .... Alternating current
- ASSY. .... Assembly
- AT. .... Automatic transmission
- C.D.I. .... Capacitive discharge ignition
- COMP. ... Complete
- D.C. .... Direct current
- EX. .... Exhaust
- G.F.C.I ... Ground fault circuit interruptor
- HEX. .... Hexagonal
- H.S.T. .... Hydrostatic transmission
- FR. ....Front
- IN. ....Inlet
- L (100L) .Link (100 Links)
- L. ....Left
- MM .....Millimeter
- MT. ....Manual Transmission
- P.T.O. ....Power take off
- R. ....Right
- RR. ....Rear
- STD. ....Standard
- T (22T) ...Tooth (22 Teeth)
- V .....Volt
- W .....Watt

How to check the part block and serial numbers

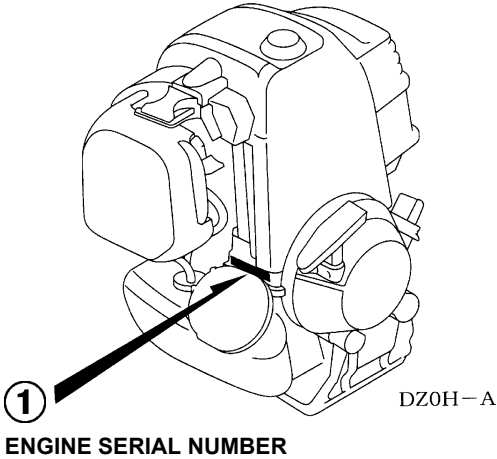
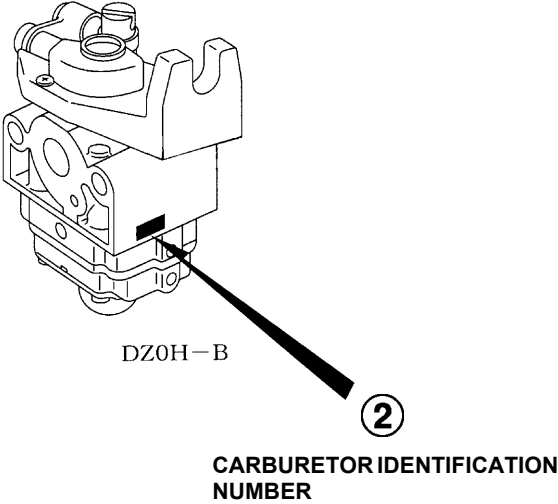
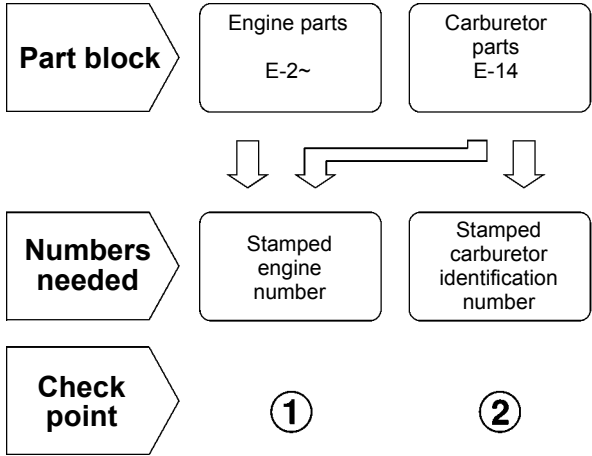



### Models, parts catalogue codes and applicable serial numbers

- Models, parts catalogue codes and applicable serial Nos. given in this parts catalogue can be identified as follows.

Model	Type	Parts catalogue type	Applicable engine serial No.	Applicable carburetor identification No.
GX25	SAT	SAT	GCAAM-1000001~1199999	WYB 6B
		SAT/A	GCAAM-1200001~	WYB 6B WYB 6C WYB 6D
	SAU	SAU	GCAAM-1000001~1199999	WYB 7B
		SAU/A	GCAAM-1200001~	WYB 7B WYB 7C
	SAUT	SAUT	GCAAM-1000001~1199999	WYB 7B
		SAUT/A	GCAAM-1200001~	WYB 7B WYB 7C
	SA2	SA2	GCAAM-1000001~1199999	WYB 6B
		SA2/A	GCAAM-1200001~	WYB 6B WYB 6C WYB 6D
	SC2	SC2	GCAAM-1000001~1199999	WYB 6B
		SC2/A	GCAAM-1200001~	WYB 6B WYB 6C WYB 6D
	SD	SD	GCAAM-1000001~1199999	WYB 7B WYB 8
		SD/A	GCAAM-1200001~	WYB 8 WYB 8A
	SDT	SDT	GCAAM-1000001~1199999	WYB 7B WYB 8
		SDT/A	GCAAM-1200001~	WYB 8 WYB 8A
	SE	SE	GCAAM-1000001~1199999	WYB 7B WYB 8
		SE/A	GCAAM-1200001~	WYB 8 WYB 6B WYB 6C WYB 6D
	SET	SET	GCAAM-1000001~1199999	WYB 7B WYB 8
		SET/A	GCAAM-1200001~	WYB 8 WYB 6B WYB 6C WYB 6D

Model	Type	Parts catalogue type	Applicable engine serial No.	Applicable carburetor identification No.
GX25	SJ	SJ	GCAAM-1000001~1199999	WYB 7B WYB 8
		SJ/A	GCAAM-1200001~	WYB 8 WYB 8A
	SJT	SJT	GCAAM-1000001~1199999	WYB 7B WYB 8
		SJT/A	GCAAM-1200001~	WYB 8 WYB 8A
	WA	WA	GCAAM-1000001~1199999	WYB 12
		WA/A	GCAAM-1200001~	WYB 12 WYB 12A WYB 12B
	WD	WD	GCAAM-1000001~1199999	WYB 10
		WD/A	GCAAM-1200001~	WYB 10 WYB 10A
	WE	WE	GCAAM-1000001~1199999	WYB 10
		WE/A	GCAAM-1200001~	WYB 10 WYB 12 WYB 12A WYB 12B
	WJ	WJ	GCAAM-1000001~1199999	WYB 10
		WJ/A	GCAAM-1200001~	WYB 10 WYB 10A
	TA	TA	GCAAM-1000001~1199999	WYB 9
		TA/A	GCAAM-1200001~	WYB 9 WYB 9A WYB 9B
	SJS	SJS	GCAAM-1000001~1199999	WYB 8
		SJS/A	GCAAM-1200001~	WYB 8 WYB 8A
	TA2	TA2	GCAAM-1000001~1199999	WYB 9
		TA2/A	GCAAM-1200001~	WYB 9 WYB 9A WYB 9B
	TD	TD	GCAAM-1000001~1199999	WYB 11
		TD/A	GCAAM-1200001~	WYB 11 WYB 11A

Model	Type	Parts catalogue type	Applicable engine serial No.	Applicable carburetor identification No.
GX25	TE	TE	GCAAM-1000001~1199999	WYB 11
		TE/A	GCAAM-1200001~	WYB 11 WYB 9 WYB 9A WYB 9B
	TJ	TJ	GCAAM-1000001~1199999	WYB 11
		TJ/A	GCAAM-1200001~	WYB 11 WYB 11A
	SUT	SUT	GCAAM-1000001~1199999	WYB 7B
		SUT/A	GCAAM-1200001~	WYB 7B WYB 7C
	SKN	SKN	GCAAM-1000001~1199999	WYB 11
		SKN/A	GCAAM-1200001~	WYB 11 WYB 11A
	SJD	SJD	GCAAM-1000001~1199999	WYB 8
		SJD/A	GCAAM-1200001~	WYB 8 WYB 8A
	HAT	HAT	GCABM-1000001~1199999	WYB 6B
		HAT/A	GCABM-1200001~1999999	WYB 6B WYB 6C WYB 6D
	SEGT	SEGT	GCAAM-1200001~	WYB 6B WYB 6C WYB 6D
	SDM	SDM		WYB 8 WYB 8A
	SAM2	SAM2		WYB 6B WYB 6C WYB 6D
	TEZ	TEZ	GCABK-1000001~	WYB 19A WYB 19B
	TEZR	TEZR		
	SATM	SATM	GCAAM-1200001~	WYB 7B WYB 7C
HUT	HUT	GCABM-2000001~	WYB 7C	

\* Of carburetor identification numbers, only the portions underlined in the example below are used for registration.

WYB 6B

Features of each type

• See the following table for the features of each type. (Items in brackets are optional)

Specifications	Model	GX25															
	Type	HAT	SAT	SAU	SAUT	SA2	SC2	SD	SDT	SE	SET	SJ	SJD	SJS	SJT	SKN	SUT
Clutch		●	●	●	●	●	●	●	●	●	●	●	●	●	●	●	●
P.T.O. shaft																	
Arrester		●	●	●	●	●	●										●
Tank guard		●	●		●				●		●				●		●
Control																	

Specifications	Model	GX25															
	Type	TA	TA2	TD	TE	TJ	WA	WD	WE	WJ	SEGT	SDM	SAM2	TEZ	TEZR	SATM	HUT
Clutch		●	●	●	●	●					●	●	●	●	●	●	●
P.T.O. shaft							●	●	●	●							
Arrester		(●)	(●)	(●)	●	(●)	●	(●)		(●)			●			●	●
Tank guard											●					●	●
Control							●	●	●	●							

## Fuel hose, general purpose hoses and vinyl hose

- The standard part fuel hose, general purpose hose and vinyl hose may be substituted by the coiled bulk part.
- When ordering the standard part fuel hose, general purpose hose and vinyl hose use the bulk part number written in the parts catalog in brackets ( ) underneath the part name.
- When exchanging the hose, cut and use at the specified length as mentioned in the part name.  
(For the method of cutting the bulk part, and method of filling out orders etc., please refer to the instructions issued with the bulk part.)

### Bulk part number of fuel hose, general purpose hose and vinyl hose.

Example: 9 5 0 0 1 - 7 5 0 0 1 - 5 0 M

**Bulk part number:**  
Refers to the bulk part.

**Marking code (fuel hose and general purpose hose)**

**Change code (Vinyl hose)**

Indicates number mark or change sequence, however, the code for the bulk part must be strictly 0 (zero).

**Types of code:**

- |             |  |                |  |              |   |
|-------------|--|----------------|--|--------------|---|
| • Fuel hose | 2: Red outside braid<br>(3 mm inside dia. only)        | • General hose | 1: Ash gray<br>2: Ash gray<br>3: Black<br>5: Black | • Vinyl hose | 1: Clear<br>2: Black<br>3: Light red<br>6: Light red<br>7: Pale black |
|             | 5: Black inside braid                                  |                |  |              |   |
|             | 3: Red (3 mm inside dia. only)                         |                |  |              |   |
|             | 4: Ash gray with red stripe<br>(3 mm inside dia. only) |                |  |              |   |
|             | 6: Black   |                |  |              |   |

**Lengths:**

- 001: 1 m (standard)  
003: 3 m  
008: 8 m } Application or specification of some parts is not settled.

**I.D code: (fuel hose and general purpose hose)**

- |            |                    |                    |                             |                             |
|------------|--------------------|--------------------|-----------------------------|-----------------------------|
| 30: 3.0 mm | 50: 5.0 mm         | 70: 7.0 mm         | 11: 11 mm                   | 12: 12 (outside dia. 17) mm |
| 35: 3.5 mm | 55: 5.3 mm, 5.5 mm | 75: 7.3 mm, 7.5 mm | 91: 12 (outside dia. 15) mm | 14: 14 mm                   |
| 45: 4.5 mm | 65: 6.5 mm         | 80: 8.0 mm         | 92: 12 (outside dia. 16) mm | 17: 17 mm                   |

**ID./OD. code: (vinyl hose)**

- |                         |                          |                           |                           |                           |
|-------------------------|--------------------------|---------------------------|---------------------------|---------------------------|
| 01: ID. 2.9, OD. 6.8 mm | 12: ID. 5.0, OD. 7.0 mm  | 21: ID. 8.0, OD. 9.0 mm   | 37: ID. 11.0, OD. 15.0 mm | 50: ID. 16.0, OD. 19.0 mm |
| 03: ID. 3.0, OD. 6.0 mm | 10: ID. 5.0, OD. 8.0 mm  | 23: ID. 8.0, OD. 12.0 mm  | 38: ID. 12.0, OD. 13.0 mm | 55: ID. 17.5, OD. 20.5 mm |
| 05: ID. 3.5, OD. 6.5 mm | 11: ID. 5.0, OD. 9.0 mm  | 25: ID. 9.0, OD. 11.0 mm  | 39: ID. 12.0, OD. 14.0 mm | 60: ID. 22.0, OD. 27.0 mm |
| 07: ID. 4.0, OD. 7.0 mm | 14: ID. 6.0, OD. 9.0 mm  | 27: ID. 9.0, OD. 13.0 mm  | 40: ID. 12.0, OD. 16.0 mm |                           |
| 08: ID. 4.5, OD. 6.5 mm | 17: ID. 7.0, OD. 9.0 mm  | 33: ID. 10.0, OD. 14.0 mm | 43: ID. 13.0, OD. 15.0 mm |                           |
| 09: ID. 4.5, OD. 8.0 mm | 19: ID. 7.0, OD. 11.0 mm | 36: ID. 11.0, OD. 13.0 mm | 45: ID. 14.0, OD. 18.0 mm |                           |

**Hose type:**

- 1: Fuel hose  
3: Vinyl hose  
5: General hose

⊙ **CAUTION: It is DANGEROUS to confuse the fuel hose with the general purpose hose or vinyl hose.**

Never use a general purpose hose or vinyl hose in place of a fuel hose or vice versa. Always use the correct bulk part in the parts catalogue, according to the service manual or the instructions issued with the bulk part.

## FLAT RATE SERVICE TIME

Flat rate service time (FRT) means the standard time required to service a product, which is listed in this manual to help the dealers control the actual working process and calculate the service charge by using it as a guide.

### FRT setting system

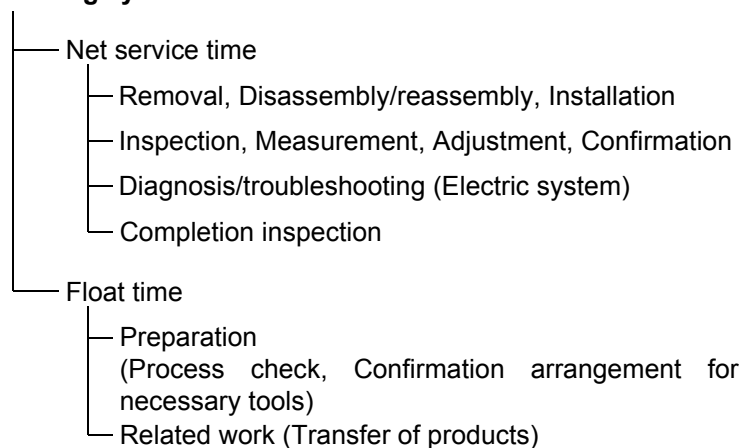

\* Float time is set by multiplying the net service time by a given coefficient.

### Editorial style

The service items shown in the text are listed with the exchange work time for the repair sales parts as the subject. Other representative service items not using repair parts (removal/installation, adjustment, inspection/measuring, and other work) are listed collectively in the list in the preface, classified according to the work.

### FRT setting standard

- Decimal system (in unit of 0.1) is adopted to set FRT as it is convenient to calculate the wage.  
Example: (0.1) → 6 minutes, (0.2) → 12 minutes  
[Labor cost per hour] x [FRT] = [Wage]
- FRT is set with a hand tool.
- Service items and FRT can be subject to change depending on development of tools and service equipment and improvement in service procedure.

**Work procedure**

- As the work procedure is set with the work time according to the method in the separate Service Manual, refer to this Manual as required.
- Work methods permitting servicing in the shortest time still permitting assurance of safe work and product warranty are used for the setting of service items not listed in the Service Manual.
- Work basically is to be performed by one person, and when two or more people are required, setting is done as the total time for the number of people.
- The set value for the technological level of the workers uses a person with three years of experience in the repair of Honda products as the standard.
- Special tools and service equipment used to set FRT are those specified or recommended in Service Manual.

**Service item whose FRT is not presented**

- Accessories and service parts that are not listed to use in this manual.
  - Locations with little aging deterioration or breakage during normal use.
  - Service work that can be finished by one touch.
  - Service work that is seldom done (i.e. extremely small causes of trouble and service frequency).
  - Products and parts whose location for installation differs according to its status of use and application.
- \* When FRT is not presented, please calculate wages based on appropriate actual work time.

**Operation not included of FRT**

- Oil and coolant water draining, Waiting time for warming up operation and etc..
- Additional operation that involves removal/installation of standard exterior equipment.
- Indirect time spent for service by visiting the customer, trade-in, and delivery.
- Indirect time required for ordering and delivery of parts.
- Cost for grease, adhesive agent, etc. used for service work.

**Explanation of FRT by using an example  
(The example may differ from the actual presented items)**

Ref. No.	L.O.N.	(Relative ref. Number) Description	F.R.T.
①	1111L1	④ (1, 3, 4, 7) VALVE, INTAKE ..... 4.1	②
②		• NOTE: OHV type ⑥	⑦
③	1111L1A	• Includes: Engine removal and installation	
		One head (intake all) add ..... 1.4 ⑤	

- ① Reference No. of the illustration of part that shows location of the replacement work.
- ② FRT is an abbreviation of Flat Rate Time indicating the standard service time required for the replacement.
- ③ LON is an abbreviation of Labor Operation Number, and it is a classification of the service items by the work unit code.

The same operation code is used regardless of the models.

Standard operation is indicated with 6 digits code, and additional operation is indicated with 7 digits code.

- ④ Indicating the intake valve replacement and FRT4.1.
- ⑤ Indicating FRT1.4 that will be added when additional operation (whole intake side of one cylinder head) is done in association with intake valve replacement.

- ⑥ Indicating work condition or application condition of the service item.
- ⑦ Indicating work contents that are included in the service item.
- ⑧ Indicating a reference No. whose operation and time are the same as FRT4.1 for the intake valve.

(The application range is limited to the service items without an LON setting within a same block.)

**How to refer to the service item by using the sample  
(intake valve replacement)**

Open to the page of the block where the intake valve's spare part illustration is shown.

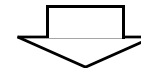

Look for the intake valve illustration, and refer to the service item and FRT that agree with the reference No.

Indication mark for the listing of service items that continues to the following page

Ref. No.	L.O.N.	(Relative ref. Number) Description	F.R.T.
2	1111L1	VALVE, INTAKE .....	4.1
	.	.	.
	.	.	.

+  
Mark indicated at the last line.

Indication of the block with no setting of FRT

Ref. No.	L.O.N.	(Relative ref. Number) Description	F.R.T.
<b>NO INFORMATION .....</b>			

• LON code system

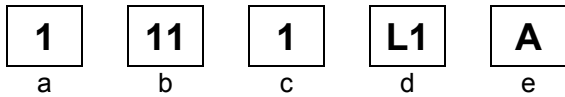

- a) Category code..... Engine
- b) Location/function code ..... Engine upper
- c) Operation code..... Replace
- d) Operation sequence number (Unit code can be shown with alphabet)  
..... Intake valve  
(No regular rule of code)
- e) Additional code ..... One head (intake all)  
(No regular rule of code)

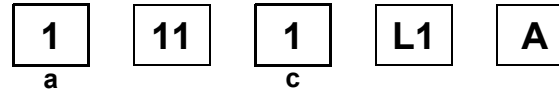

a) Category codes and classification

Code	Category
1	Engine
2	Power drive
3	Fuel & Exhaust
4	Frame & Body
5	Steering
6	Electrical
7	Axle & Brake
8	Control system
9	-
0	Attachments

c) Operation codes and classification

Code	Operation category
1	Replace, Removal/Installation, Change
2	Overhaul
3	Adjust, Rotation
4	(Paint-related work: Top-coat)
5	Test, Inspect/diagnose, Measurement
6	(Overhaul-related work: Rebore)
7	(Overhaul-related work: Reseal)
8	(Resurface)
9	(Paint-related work: Refinish)
0	Repair, Cleaning, Air bleeding



Major service items without using spare parts

(1) Removal/Installation, (2) Adjustment, (3) Inspection/Measurement, (4) Overhaul, (5) Other work

E: Engine, T: Transmission, D: Drive system, B: Body and related parts

## (2) Adjustment

	LON	DESCRIPTION	FRT
E	1113A1	<b>VALVE CLEARANCE-ADJUSTMENT</b> NOTE: For 1 product	0.2
	3113A2	<b>CARBURETOR IDLE-ADJUSTMENT</b>	0.2

## (3) Inspection, Measurement, Cleaning

	LON	DESCRIPTION	FRT
E	1105A0	<b>ENGINE OIL-INSPECTION</b>	0.1
	3120A0	<b>AIR CLEANER-CLEANING</b> INCLUDES: Air cleaner-inspection	0.1
	3130A0	<b>SPARK ARRESTER-CLEANING</b>	0.1
	6140A0	<b>SPARK PLUG-ADJUSTMENT/CLEANING</b> NOTE: For 1 product	0.2

## (4) Overhaul

Work condition: The required Measurements, inspections, adjustments, and cleaning/washing of each part are performed, including the main body removal/installation work and the replacement of defective parts.

	LON	DESCRIPTION	FRT
E	3112A0	<b>CARBURETOR-OVERHAUL</b> INCLUDES: All necessary adjustment	0.4

# ENGINE GROUP

**B15**

**E-2**

**CRANKCASE SET**

**C 1**

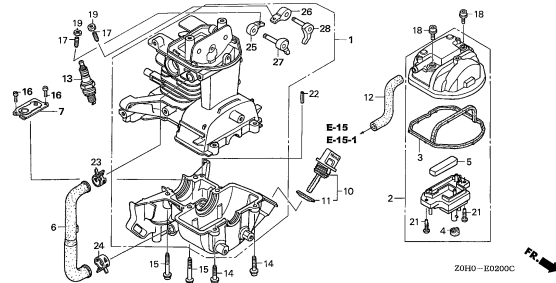

FR →

**E-7**

**CRANKSHAFT/PISTON**

**C 3**

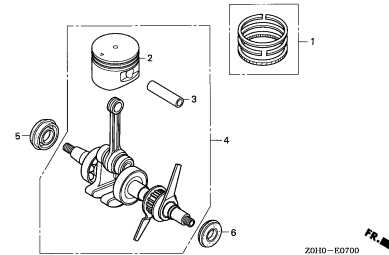

FR →

**E-10**

**CAM PULLEY**

**C 4**

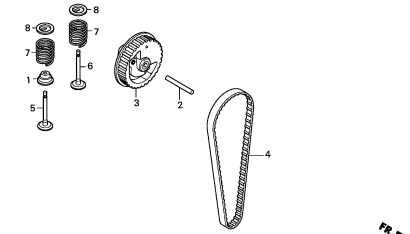

FR →

**E-11**

**RECOIL STARTER**

**C 5**

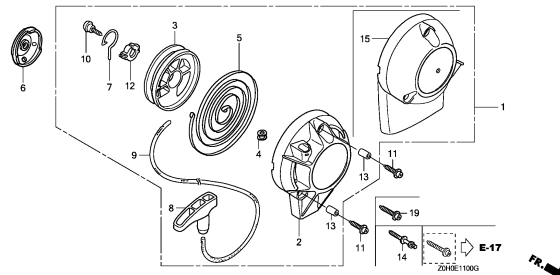

FR →

**E-12**

**FAN COVER/CLUTCH**

**C 7**

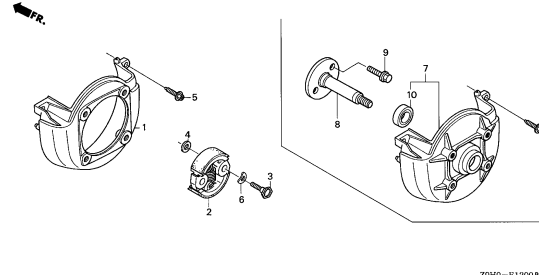

FR →

**E-14**

**CARBURETOR**

**C 9**

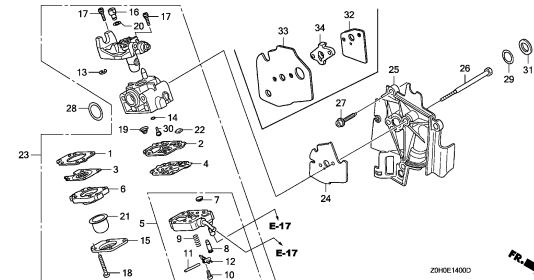

FR →

**E-15**

**AIR CLEANER(1)**

**C14**

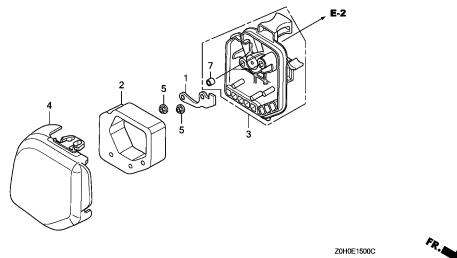

FR →

**E-15-1**

**AIR CLEANER(2)**

**C15**

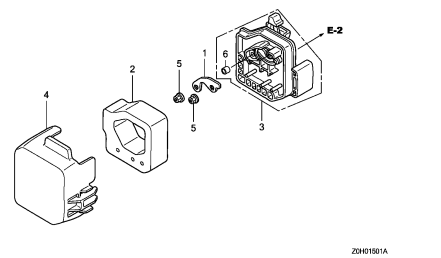

FR →

**E-16**

**MUFFLER**

**C16**

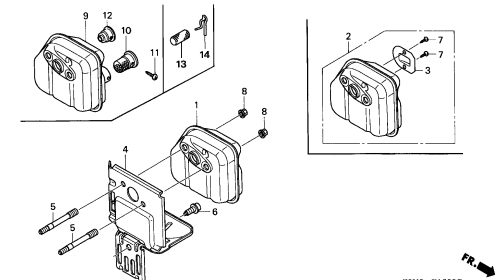

FR →

**2**

# ENGINE GROUP

**B16**

**E-17**

**FUEL TANK**

**D 1**

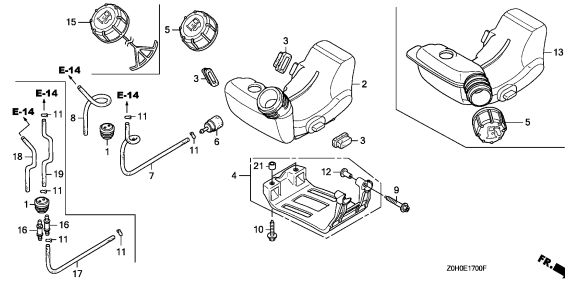

Z0H0E1700F



**E-19**

**FLYWHEEL**

**D 4**

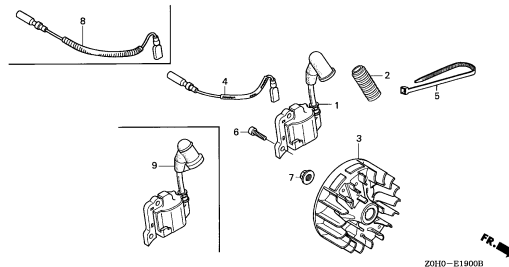

Z0H0-E1900B



**E-22**

**CONTROL**

**D 6**

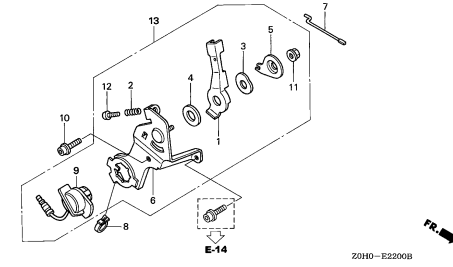

Z0H0-E2200B



**E-27**

**TOP COVER**

**D 7**

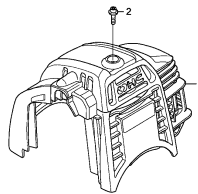

Z0H0E2700C



**E-28**

**LABEL**

**D 8**

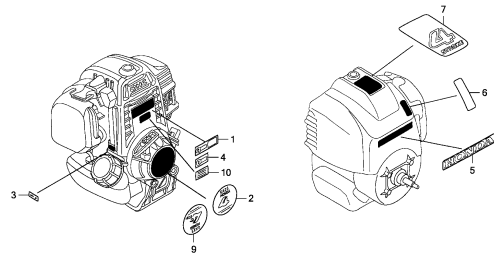

Z0H0E2800G

**E-29**

**TOOL**

**D10**

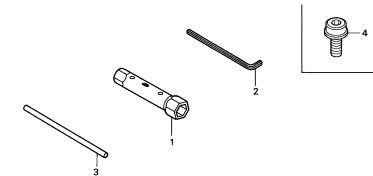

Z0H0-E2900 A

**2**

E-2

CRANKCASE SET

C 1

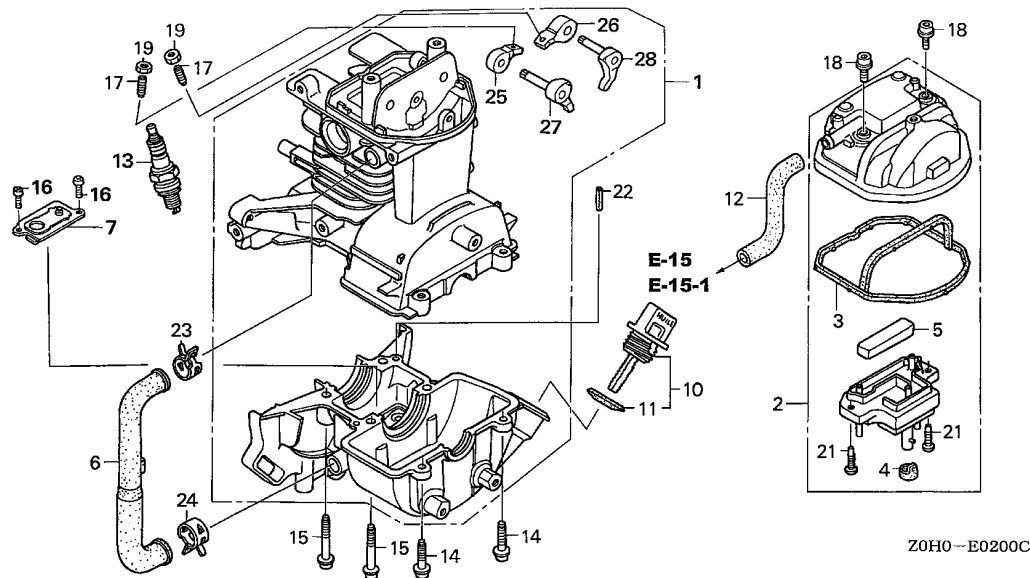

Ref. No.	L.O.N.	(Relative ref. Number) Description	F.R.T.
1	1101B7	CRANKCASE .....	1.5
2	1111D5	COVER, CYLINDER HEAD AND/OR PACKING, HEAD COVER .....	0.1
6	1171A4	TUBE, OIL .....	0.3
7	1171A2	PLATE, OIL OUTLET VALVE .....	1.1
12	1111K5	TUBE, BREATHER .....	0.1
13	6141C1	PLUG, SPARK .....	0.1
25	1111A2	ARM, ROCKER :INTAKE .....	0.6
		.INCLUDES: Valve clearance adjustment	
26	1111A1	ARM, ROCKER :EXHAUST .....	0.6
		.INCLUDES: Valve clearance adjustment	
27	1111L9	LIFTER, VALVE :INTAKE .....	0.6
		.INCLUDES: Valve clearance adjustment	
28	1111M0	LIFTER, VALVE :EXHAUST .....	0.6
		.INCLUDES: Valve clearance adjustment	

Ref. No.	Part No.	Description	Reqd. QTY	Serial No.	Parts catalogue code
			GX 25		
1	10100-ZOH-415	CRANKCASE SET .....	1	-----	SAT,SAU,SAUT,SA2,SC2,SD,SDT,SE,SET,SJ,SJD,SJS,SJT,SKN,SUT,TA,TA2,TD,TE,TJ WA,WD,WE,WJ
			1	1208427	SAT/A,SAU/A,SAUT/A,SA2/A,SC2/A,SD/A,SDT/A,SE/A,SET/A,SJ/A,SJD/A,SJS/A SJT/A,SKN/A,SUT/A,TA/A,TA2/A,TD/A,TE/A,TJ/A
	10100-ZOH-425	.....	1	1220677	WA/A,WD/A,WE/A,WJ/A
			1	1208428	HAT,HAT/A,HUT,SAM2,SATM,SDM,SEGT,TEZ,TEZR SAT/A,SAU/A,SAUT/A,SA2/A,SC2/A,SD/A,SDT/A,SE/A,SET/A,SJ/A,SJD/A,SJS/A SJT/A,SKN/A,SUT/A,TA/A,TA2/A,TD/A,TE/A,TJ/A
			1	1220678	WA/A,WD/A,WE/A,WJ/A
2	12310-ZOH-010	COVER, CYLINDER HEAD .....	1		
3	12312-ZOH-300	SEAL, HEAD COVER .....	1		
4	12314-ZOH-300	GROMMET, HEAD COVER .....	1		
5	12367-ZOH-000	FILTER, BREATHER .....	1		
6	15422-ZOH-000	TUBE, OIL .....	1		
7	15510-ZOH-000	PLATE ASSY., OIL OUTLET VALVE	1		
10	15600-ZFO-003	CAP ASSY., OIL FILLER .....	1		
11	15625-ZE1-003	PACKING, OIL FILLER CAP .....	1		
12	15721-ZOH-000	TUBE, BREATHER .....	1	-----	HAT,HAT/A,HUT,SAT,SAT/A,SATM,SAU,SAU/A,SAUT,SAUT/A,SA2,SA2/A,SC2,SC2/A,SD SD/A,SDT,SDT/A,SE,SE/A,SEGT,SET,SET/A,SJ,SJ/A,SJD,SJS,SJS/A,SJT,SJT/A,SKN SUT,SUT/A,TA,TA2,TD,TE,TJ
	15721-ZOH-800	.....	1	1230202	SJD/A
			1	-----	SAM2,SDM,WA,WA/A,WD,WD/A,WE,WE/A,WJ,WJ/A
			1	1230203	SJD/A
	15721-ZOH-820	.....	1	-----	SKN/A,TA/A,TA2/A,TD/A,TE/A,TEZ,TEZR,TJ/A
13	31914-ZOH-003	PLUG, SPARK (CMR4H) (NGK) .....	(1)	-----	HAT,HAT/A,HUT,SAM2,SAT,SAT/A,SATM,SAU,SAU/A,SAUT,SAUT/A,SA2,SA2/A,SC2 SC2/A,SD,SD/A,SDM,SDT,SDT/A,SE,SE/A,SEGT,SET,SET/A,SUT,SUT/A,TA,TA/A,TA2 TA2/A,TD,TD/A,TE,TE/A,TEZ,TEZR,WA,WA/A,WD,WD/A,WE,WE/A

2

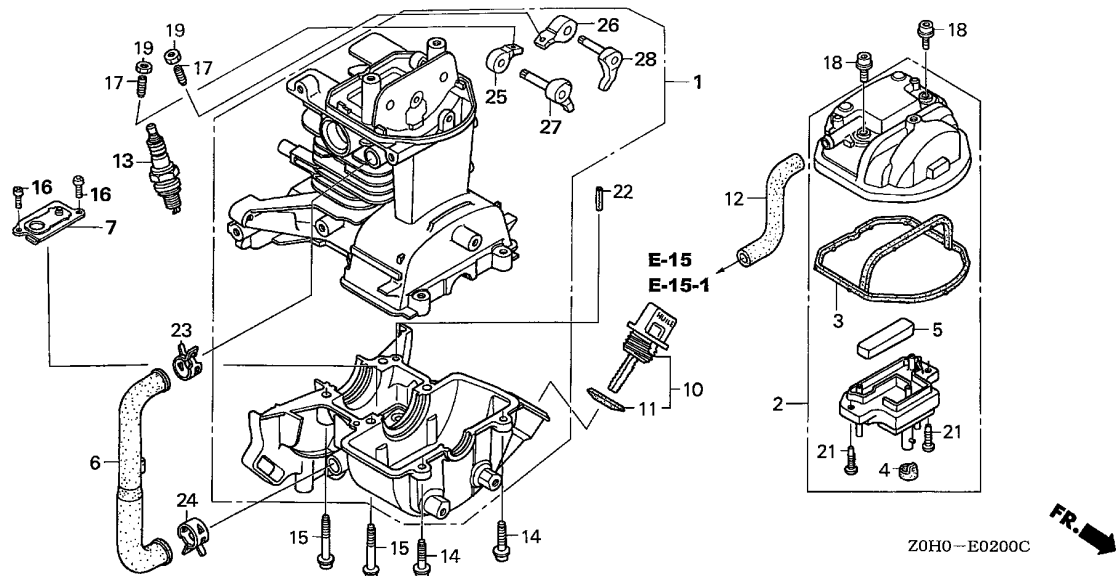

2

Ref. No.	Part No.	Description	Reqd. QTY		Serial No.	Parts catalogue code
			GX	25		
13)	31914-ZOH-801	PLUG, SPARK (CM4H) (NGK) .....	(1)	-----	-----	SJ,SJ/A,SJD,SJD/A,SJS,SJS/A,SJT,SJT/A,SKN,SKN/A,TJ,TJ/A,WJ,WJ/A
	31915-ZOH-003	PLUG, SPARK (CMR5H) (NGK) .....	1	-----	-----	HAT,HAT/A,HUT,SAM2,SAT,SAT/A,SATM,SAU,SAU/A,SAUT,SAUT/A,SA2,SA2/A,SC2 SC2/A,SD,SD/A,SDM,SDT,SDT/A,SE,SE/A,SEGT,SET,SET/A,SUT,SUT/A,TA,TA/A,TA2 TA2/A,TD,TD/A,TE,TE/A,TEZ,TEZR,WA,WA/A,WD,WD/A,WE,WE/A
	31915-ZOH-801	PLUG, SPARK (CM5H) (NGK) .....	1	-----	-----	SJ,SJ/A,SJD,SJD/A,SJS,SJS/A,SJT,SJT/A,SKN,SKN/A,TJ,TJ/A,WJ,WJ/A
	31916-ZOH-003	PLUG, SPARK (CMR6H) (NGK) .....	(1)	-----	-----	HAT,HAT/A,HUT,SAM2,SAT,SAT/A,SATM,SAU,SAU/A,SAUT,SAUT/A,SA2,SA2/A,SC2 SC2/A,SD,SD/A,SDM,SDT,SDT/A,SE,SE/A,SEGT,SET,SET/A,SUT,SUT/A,TA,TA/A,TA2 TA2/A,TD,TD/A,TE,TE/A,TEZ,TEZR,WA,WA/A,WD,WD/A,WE,WE/A
	31916-ZOH-801	PLUG, SPARK (CM6H) (NGK) .....	(1)	-----	-----	SJ,SJ/A,SJD,SJD/A,SJS,SJS/A,SJT,SJT/A,SKN,SKN/A,TJ,TJ/A,WJ,WJ/A
14	90009-ZOH-003	BOLT, SOCKET, 5X20 .....	2	-----	-----	
15	90010-ZOH-003	BOLT, SOCKET, 5X30 .....	4	-----	-----	
16	90013-ZOH-004	SCREW, PAN, 4X8 .....	2	-----	-----	
17	90017-ZOH-000	SCREW, TAPPET ADJUSTING .....	2	-----	-----	
18	90019-ZOH-003	BOLT, SOCKET, 5X12 .....	2	-----	-----	
19	90206-ZM3-000	NUT, TAPPET ADJUSTING .....	2	-----	-----	
21	93901-34320	SCREW, TAPPING, 4X12 .....	2	-----	-----	
22	94305-40102	PIN, SPRING, 4X10 .....	1	-----	-----	
23	95002-41200-08	CLAMP, TUBE (D12) .....	1	-----	-----	
24	95002-41300-04	CLAMP, TUBE (D13) .....	1	-----	-----	
25	14431-ZOH-003	ARM, IN. VALVE ROCKER .....	1	-----	-----	
26	14441-ZOH-003	ARM, EX. VALVE ROCKER .....	1	-----	-----	
27	14730-ZOH-000	LIFTER COMP., IN. VALVE .....	1	-----	-----	
28	14740-ZOH-000	LIFTER COMP., EX. VALVE .....	1	-----	-----	

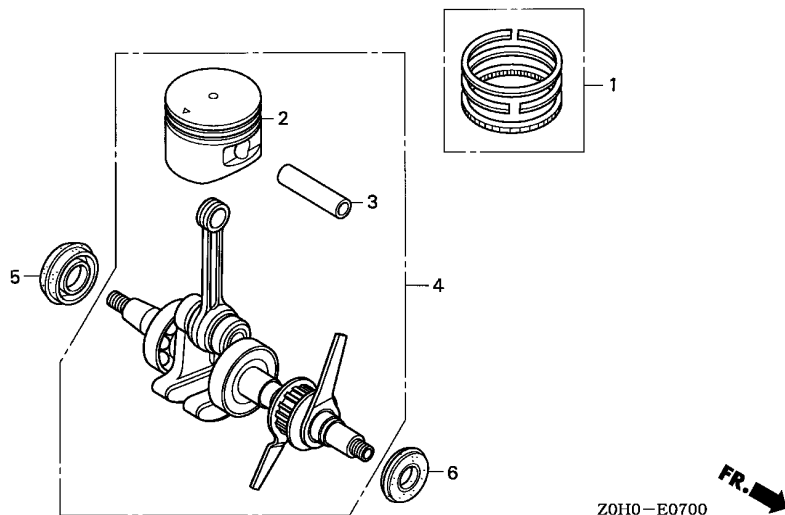

Ref. No.	L.O.N.	(Relative ref. Number) Description	F.R.T.
1	(2,3)		
	1111J4	RING SET, PISTON .....	1.3
	1111J4F	.Replace 1 piston and/or pin and/or rod, connecting and/or bearing add .....	0.1
4	1101F0	CRANKSHAFT .....	1.2
5	1101E5	OIL SEAL, CRANKSHAFT :REAR ...	1.2
6	1101E4	OIL SEAL, CRANKSHAFT :FRONT ..	1.2

Ref. No.	Part No.	Description	Reqd. QTY	GX	Serial No.	Parts catalogue code
				25		
1	13010-ZOH-000	RING SET, PISTON .....	1			
2	13101-ZOH-000	PISTON .....	1			
3	13111-ZOH-000	PIN, PISTON .....	1			
4	13310-ZOH-010	CRANKSHAFT COMP. ....	1			
			1		----- SAT,SAU,SAUT,SA2,SC2,SD,SDT,SE,SET,SJ,SJD,SJS,SJT,SKN,SUT,TA,TA2,TD,TE,TJ	
			1		1208427 SAT/A,SAU/A,SAUT/A,SA2/A,SC2/A,SD/A,SDT/A,SE/A,SET/A,SJ/A,SJD/A,SJS/A	
			1		SJT/A,SKN/A,SUT/A,TA/A,TA2/A,TD/A,TE/A,TJ/A	
	13310-ZOH-020	.....	1		----- HAT,HAT/A,HUT,SAM2,SATM,SDM,SEGT,TEZ,TEZR	
			1		1208428 SAT/A,SAU/A,SAUT/A,SA2/A,SC2/A,SD/A,SDT/A,SE/A,SET/A,SJ/A,SJD/A,SJS/A	
			1		SJT/A,SKN/A,SUT/A,TA/A,TA2/A,TD/A,TE/A,TJ/A	
	13310-ZOH-800	.....	1		----- WA,WD,WE,WJ	
			1		1220677 WA/A,WD/A,WE/A,WJ/A	
	13310-ZOH-801	.....	1		1220678 WA/A,WD/A,WE/A,WJ/A	
5	91211-ZOH-003	OIL SEAL, 12X24X5 .....	1			
6	91212-ZOH-003	OIL SEAL, 10X20X5 .....	1			



E-10

CAM PULLEY

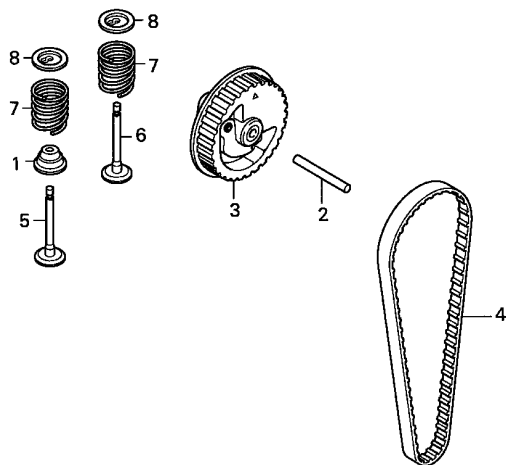

ZOH0-E1000 **FR.** →

Ref. No.	L.O.N.	(Relative ref. Number) Description	F.R.T.
1	1111K2	SEAL, INTAKE VALVE STEM .....	1.2
3	1111N5	PULLEY, CAMSHAFT .....	0.4
		.INCLUDES: Valve clearance adjustment	
4	1111N6	BELT, TIMING .....	1.2
5	1111L1	VALVE, INTAKE .....	1.3
		.INCLUDES: Valve clearance adjustment	
		1111L1E .Replace intake and exhaust all add .....	0.1
6	1111L0	VALVE, EXHAUST .....	1.3
		.INCLUDES: Valve clearance adjustment	
		1111L0E .Replace intake and exhaust all add .....	0.1
7	1111P3	SPRING, VALVE :INTAKE .....	1.2
		.INCLUDES: Valve clearance adjustment	
		1111P3A .Replace intake and exhaust all add .....	0.1
		1111P4 SPRING, VALVE :EXHAUST .....	1.2
		.INCLUDES: Valve clearance adjustment	
		1111P4A .Replace intake and exhaust all add .....	0.1

Ref. No.	Part No.	Description	Reqd. QTY	Serial No.	Parts catalogue code
			GX 25		
1	12209-ZOH-003	SEAL, VALVE STEM .....	1		
2	14126-ZOH-003	ROLLER, 4X29.8 .....	1		
3	14320-ZOH-000	PULLEY COMP., CAMSHAFT .....	1	----- 1073685	SAT,SAU,SAUT,SA2,SC2,SD,SDT,SE,SET,SJ,SJD,SJS,SJT,SKN,SUT,TA,TA2,TD,TE,TJ WA,WD,WE,WJ
	14320-ZOH-010	.....	1	-----	HAT,HAT/A,HUT,SAM2,SAT/SATM,SAU/A,SAUT/A,SA2/A,SC2/A,SD/A,SDM,SDT/A SE/A,SEGT,SET/A,SJ/A,SJD/A,SJS/A,SJT/A,SKN/A,SUT/A,TA/A,TA2/A,TD/A,TE/A TEZ,TEZR,TJ/A,WA/A,WD/A,WE/A,WJ/A
			1	1073686	----- SAT,SAU,SAUT,SA2,SC2,SD,SDT,SE,SET,SJ,SJD,SJS,SJT,SKN,SUT,TA,TA2,TD,TE,TJ WA,WD,WE,WJ
4	14400-ZOH-003	BELT, TIMING (71ZU6 G-300) ..	1		
5	14711-ZOH-000	VALVE, IN. ....	1	-----	HAT,HAT/A,SAM2,SAT,SAT/A,SAU,SAU/A,SAUT,SAUT/A,SA2,SA2/A,SC2,SC2/A,SD SD/A,SDM,SDT,SDT/A,SE,SE/A,SEGT,SET,SET/A,SJ,SJ/A,SJD,SJD/A,SJS,SJS/A,SJT SJT/A,SKN,SKN/A,SUT,SUT/A,TA,TA/A,TA2,TA2/A,TD,TD/A,TE,TE/A,TJ,TJ/A,WA WA/A,WD,WD/A,WE,WE/A,WJ,WJ/A
	14711-ZOH-800	.....	1	----- 1001329	TEZ,TEZR
			1	-----	HUT,SATM
			1	1001330	----- TEZ,TEZR
6	14721-ZOH-000	VALVE, EX. ....	1	-----	HAT,HAT/A,SAM2,SAT,SAT/A,SAU,SAU/A,SAUT,SAUT/A,SA2,SA2/A,SC2,SC2/A,SD SD/A,SDM,SDT,SDT/A,SE,SE/A,SEGT,SET,SET/A,SJ,SJ/A,SJD,SJD/A,SJS,SJS/A,SJT SJT/A,SKN,SKN/A,SUT,SUT/A,TA,TA/A,TA2,TA2/A,TD,TD/A,TE,TE/A,TEZ,TEZR,TJ TJ/A,WA,WA/A,WD,WD/A,WE,WE/A,WJ,WJ/A
	14721-ZOH-800	.....	1	-----	HUT,SATM
7	14751-ZOH-000	SPRING, VALVE .....	2		
8	14771-ZOH-000	RETAINER, VALVE SPRING .....	2		

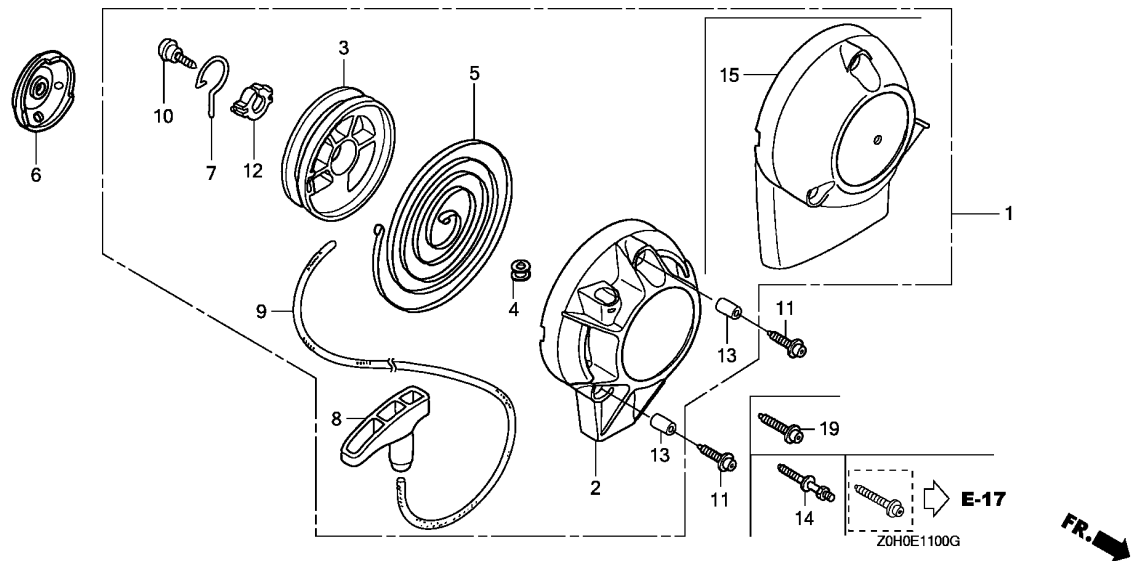

Ref. No.	L.O.N.	(Relative ref. Number) Description	F.R.T.
1	1121B9	STARTER, RECOIL .....	0.1
3	1121B1	REEL, RECOIL STARTER .....	0.3
5	1121B7	SPRING, RECOIL STARTER RETURN .....	0.3
6	1121A9	PULLEY, RECOIL STARTER .....	0.3
8	1121A3	GRIP, RECOIL STARTER .....	0.1
9	1121B3	ROPE, RECOIL STARTER .....	0.3

Ref. No.	Part No.	Description	Reqd. QTY	Serial No.	Parts catalogue code
			GX 25		
1	28400-ZOH-003	STARTER ASSY., RECOIL .....	1	-----	SAM2,SAT,SAT/A,SATM,SAU,SAU/A,SAUT,SAUT/A,SA2,SA2/A,SC2,SC2/A,SD,SD/A,SDM SDT,SDT/A,SE,SE/A,SEGT,SET,SET/A,SJ,SJ/A,SJD,SJD/A,SJS,SJS/A,SJT,SJT/A SKN,SKN/A,SUT,SUT/A,TA,TA/A,TA2,TA2/A,TD,TD/A,TE,TE/A,TEZ,TJ,TJ/A,WA,WA/A WD,WD/A,WE,WE/A,WJ,WJ/A
	28400-ZOH-801	.....	1	-----	TEZR
2	28414-ZOH-003	CASE, RECOIL STARTER .....	1	-----	SAM2,SAT,SAT/A,SATM,SAU,SAU/A,SAUT,SAUT/A,SA2,SA2/A,SC2,SC2/A,SD,SD/A,SDM SDT,SDT/A,SE,SE/A,SEGT,SET,SET/A,SJ,SJ/A,SJD,SJD/A,SJS,SJS/A,SJT,SJT/A SKN,SKN/A,SUT,SUT/A,TA,TA/A,TA2,TA2/A,TD,TD/A,TE,TE/A,TEZ,TJ,TJ/A,WA,WA/A WD,WD/A,WE,WE/A,WJ,WJ/A
3	28421-ZOH-003	REEL, RECOIL STARTER .....	1	-----	SAM2,SAT,SAT/A,SATM,SAU,SAU/A,SAUT,SAUT/A,SA2,SA2/A,SC2,SC2/A,SD,SD/A,SDM SDT,SDT/A,SE,SE/A,SEGT,SET,SET/A,SJ,SJ/A,SJD,SJD/A,SJS,SJS/A,SJT,SJT/A SKN,SKN/A,SUT,SUT/A,TA,TA/A,TA2,TA2/A,TD,TD/A,TE,TE/A,TEZ,TEZR,TJ,TJ/A,WA WA/A,WD,WD/A,WE,WE/A,WJ,WJ/A
4	28433-ZM3-003	GUIDE, ROPE .....	1	-----	SAM2,SAT,SAT/A,SATM,SAU,SAU/A,SAUT,SAUT/A,SA2,SA2/A,SC2,SC2/A,SD,SD/A,SDM SDT,SDT/A,SE,SE/A,SEGT,SET,SET/A,SJ,SJ/A,SJD,SJD/A,SJS,SJS/A,SJT,SJT/A SKN,SKN/A,SUT,SUT/A,TA,TA/A,TA2,TA2/A,TD,TD/A,TE,TE/A,TEZ,TEZR,TJ,TJ/A,WA WA/A,WD,WD/A,WE,WE/A,WJ,WJ/A
5	28442-ZOH-003	SPRING, RECOIL STARTER .....	1	-----	SAM2,SAT,SAT/A,SATM,SAU,SAU/A,SAUT,SAUT/A,SA2,SA2/A,SC2,SC2/A,SD,SD/A,SDM SDT,SDT/A,SE,SE/A,SEGT,SET,SET/A,SJ,SJ/A,SJD,SJD/A,SJS,SJS/A,SJT,SJT/A SKN,SKN/A,SUT,SUT/A,TA,TA/A,TA2,TA2/A,TD,TD/A,TE,TE/A,TEZ,TEZR,TJ,TJ/A,WA WA/A,WD,WD/A,WE,WE/A,WJ,WJ/A
6	28451-ZOH-003	PULLEY, RECOIL STARTER .....	1	-----	SAM2,SAT,SAT/A,SATM,SAU,SAU/A,SAUT,SAUT/A,SA2,SA2/A,SC2,SC2/A,SD,SD/A,SDM SDT,SDT/A,SE,SE/A,SEGT,SET,SET/A,SJ,SJ/A,SJD,SJD/A,SJS,SJS/A,SJT,SJT/A SKN,SKN/A,SUT,SUT/A,TA,TA/A,TA2,TA2/A,TD,TD/A,TE,TE/A,TEZ,TEZR,TJ,TJ/A,WA WA/A,WD,WD/A,WE,WE/A,WJ,WJ/A
7	28459-ZOH-003	ARM, SWING .....	1	-----	SAM2,SAT,SAT/A,SATM,SAU,SAU/A,SAUT,SAUT/A,SA2,SA2/A,SC2,SC2/A,SD,SD/A,SDM SDT,SDT/A,SE,SE/A,SEGT,SET,SET/A,SJ,SJ/A,SJD,SJD/A,SJS,SJS/A,SJT,SJT/A SKN,SKN/A,SUT,SUT/A,TA,TA/A,TA2,TA2/A,TD,TD/A,TE,TE/A,TEZ,TEZR,TJ,TJ/A,WA WA/A,WD,WD/A,WE,WE/A,WJ,WJ/A





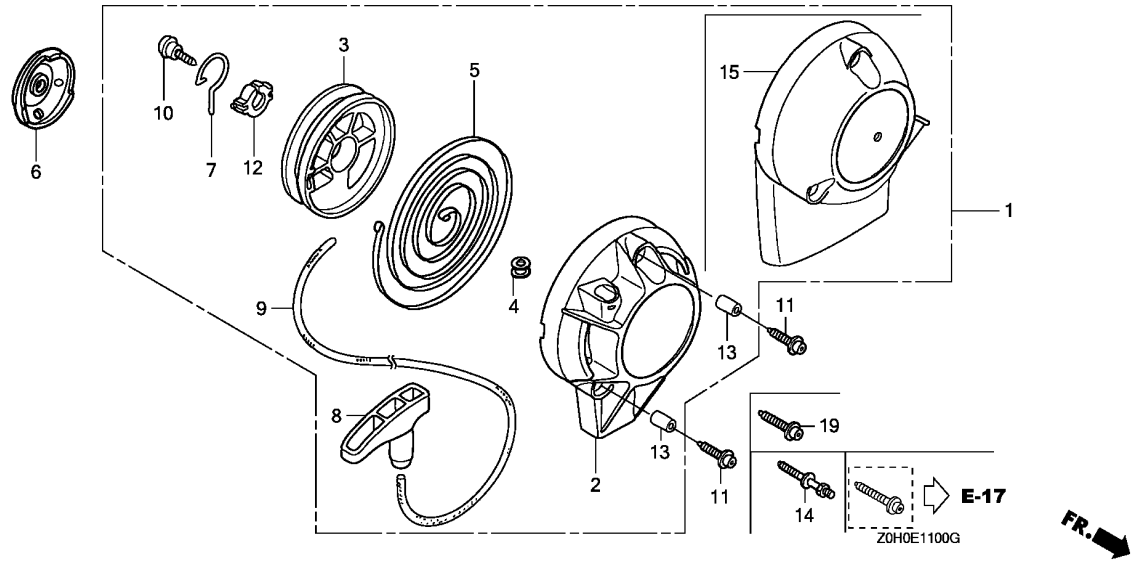

Ref. No.	Part No.	Description	Reqd. QTY		Serial No.	Parts catalogue code
			GX	25		
8	28461-ZM3-003	KNOB, RECOIL STARTER .....	1	-----	-----	SAM2,SAT,SAT/A,SATM,SAU,SAU/A,SAUT,SAUT/A,SA2,SA2/A,SC2,SC2/A,SD,SD/A,SDM SDT,SDT/A,SE,SE/A,SEGT,SET,SET/A,SJ,SJ/A,SJD,SJD/A,SJS,SJS/A,SJT,SJT/A SKN,SKN/A,SUT,SUT/A,TA,TA/A,TA2,TA2/A,TD,TD/A,TE,TE/A,TEZ,TEZR,TJ,TJ/A,WA WA/A,WD,WD/A,WE,WE/A,WJ,WJ/A
9	28462-ZM3-003	ROPE, RECOIL STARTER .....	1	-----	-----	SAM2,SAT,SAT/A,SATM,SAU,SAU/A,SAUT,SAUT/A,SA2,SA2/A,SC2,SC2/A,SD,SD/A,SDM SDT,SDT/A,SE,SE/A,SEGT,SET,SET/A,SJ,SJ/A,SJD,SJD/A,SJS,SJS/A,SJT,SJT/A SKN,SKN/A,SUT,SUT/A,TA,TA/A,TA2,TA2/A,TD,TD/A,TE,TE/A,TEZ,TEZR,TJ,TJ/A,WA WA/A,WD,WD/A,WE,WE/A,WJ,WJ/A
10	90012-ZM3-003	SCREW, SETTING .....	1	-----	-----	SAM2,SAT,SAT/A,SATM,SAU,SAU/A,SAUT,SAUT/A,SA2,SA2/A,SC2,SC2/A,SD,SD/A,SDM SDT,SDT/A,SE,SE/A,SEGT,SET,SET/A,SJ,SJ/A,SJD,SJD/A,SJS,SJS/A,SJT,SJT/A SKN,SKN/A,SUT,SUT/A,TA,TA/A,TA2,TA2/A,TD,TD/A,TE,TE/A,TEZ,TEZR,TJ,TJ/A,WA WA/A,WD,WD/A,WE,WE/A,WJ,WJ/A
11	90018-ZOH-003	BOLT, SOCKET, 5X16 .....	1	-----	-----	HAT,HAT/A,HUT,SAT,SAT/A,SATM,SAUT,SAUT/A,SDT,SDT/A,SEGT,SET,SET/A,SJS SJS/A,SJT,SJT/A,SUT,SUT/A
			3	-----	-----	SAM2,SAU,SAU/A,SA2,SA2/A,SC2,SC2/A,SD,SD/A,SDM,SE,SE/A,SJ,SJ/A,SJD,SJD/A SKN,SKN/A,TA,TA/A,TA2,TA2/A,TD,TD/A,TE,TE/A,TEZ,TEZR,TJ,TJ/A,WA,WA/A,WD WD/A,WE,WE/A,WJ,WJ/A
12	91504-ZM3-003	COLLAR .....	1	-----	-----	SAM2,SAT,SAT/A,SATM,SAU,SAU/A,SAUT,SAUT/A,SA2,SA2/A,SC2,SC2/A,SD,SD/A,SDM SDT,SDT/A,SE,SE/A,SEGT,SET,SET/A,SJ,SJ/A,SJD,SJD/A,SJS,SJS/A,SJT,SJT/A SKN,SKN/A,SUT,SUT/A,TA,TA/A,TA2,TA2/A,TD,TD/A,TE,TE/A,TEZ,TEZR,TJ,TJ/A,WA WA/A,WD,WD/A,WE,WE/A,WJ,WJ/A
13	91506-ZM3-000	COLLAR A, HEAD COVER .....	3	-----	-----	SAM2,SAT,SAT/A,SATM,SAU,SAU/A,SAUT,SAUT/A,SA2,SA2/A,SC2,SC2/A,SD,SD/A,SDM SDT,SDT/A,SE,SE/A,SEGT,SET,SET/A,SJ,SJ/A,SJD,SJD/A,SJS,SJS/A,SJT,SJT/A SKN,SKN/A,SUT,SUT/A,TA,TA/A,TA2,TA2/A,TD,TD/A,TE,TE/A,TEZ,TEZR,TJ,TJ/A,WA WA/A,WD,WD/A,WE,WE/A,WJ,WJ/A
14	90043-ZOH-000	BOLT, STUD, B .....	2	-----	-----	SJS,SJS/A
15	28414-ZOH-801	CASE, RECOIL STARTER .....	1	-----	-----	TEZR
22	19 90009-ZOH-003	BOLT, SOCKET, 5X20 .....	2	-----	-----	HAT,HAT/A,HUT

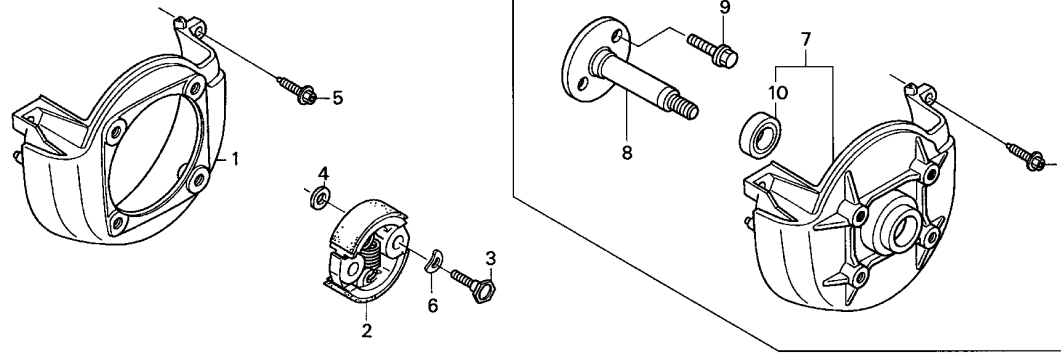

Z0H0-E1200B

Ref. No.	L.O.N.	(Relative ref. Number) Description	F.R.T.
1	1141G8	COVER, ENGINE COOLING FAN ....	0.1
2	2121F7	CLUTCH, CENTRIFUGAL .....	0.3
8	2141H4	SHAFT, POWER TAKE OFF .....	0.3

Ref. No.	Part No.	Description	Reqd. QTY	Serial No.	Parts catalogue code
			GX 25		
1	19611-Z0H-000	COVER, FAN .....	1	-----	HAT, HAT/A, HUT, SAM2, SAT, SAT/A, SATM, SAU, SAU/A, SAUT, SAUT/A, SA2, SA2/A, SC2, SC2/A, SD, SD/A, SDM, SDT, SDT/A, SE, SE/A, SEGT, SET, SET/A, SJ, SJ/A, SJD, SJD/A, SJS, SJS/A, SJT, SJT/A, SKN, SKN/A, SUT, SUT/A, TA, TA/A, TA2, TA2/A, TD, TD/A, TE, TE/A, TEZ, TEZR, TJ, TJ/A
2	22000-Z0H-003	CLUTCH ASSY. ....	1	-----	SAT, SAU, SAUT, SA2, SC2, SD, SDT, SE, SET, SJ, SJT
	22000-Z0H-801	.....	1	-----	SJD
	22000-ZM3-003	.....	1	-----	SJD/A
	22000-Z0H-U61	.....	1	1017821	HAT, HAT/A, HUT, SAT/A, SATM, SAU/A, SAUT/A, SA2/A, SC2/A, SD/A, SDT/A, SE/A, SEGT, SET/A, SJ/A, SJS, SJS/A, SJT/A, SKN, SKN/A, SUT, SUT/A, TA, TA/A, TA2, TA2/A, TD, TD/A, TE, TE/A, TJ, TJ/A
	22000-Z0H-811	.....	1	-----	SAT, SAU, SAUT, SA2, SC2, SD, SDT, SE, SET, SJ, SJT
3	22253-ZM3-003	BOLT, CLUTCH (6MM) .....	2	-----	SAM2, SDM
	22253-Z0H-003	.....	2	-----	SJD/A
	22253-Z0H-U61	.....	2	1017821	SJD/A
	22253-Z0H-U61	.....	2	-----	TEZ, TEZR
	22253-Z0H-U61	.....	2	-----	SAT, SAU, SAUT, SA2, SC2, SD, SDT, SE, SET, SJ, SJT
	22253-Z0H-U61	.....	2	-----	SJD/A
	22253-Z0H-U61	.....	2	-----	SAM2, SDM
	22253-Z0H-U61	.....	2	-----	SJD/A
4	22254-ZM3-003	WASHER, CLUTCH (6X15) .....	2	-----	HAT, HAT/A, HUT, SAT, SAT/A, SATM, SAU, SAU/A, SAUT, SAUT/A, SA2, SA2/A, SC2, SC2/A, SD, SD/A, SDT, SDT/A, SE, SE/A, SEGT, SET, SET/A, SJ, SJ/A, SJD, SJS, SJS/A, SJT, SJT/A, SKN, SKN/A, SUT, SUT/A, TA, TA/A, TA2, TA2/A, TD, TD/A, TE, TE/A, TEZ, TEZR, TJ, TJ/A
	22254-Z0H-U61	WASHER, CLUTCH (6X16.5) .....	2	-----	SJD/A
	22254-Z0H-U61	.....	2	-----	SAM2, SDM
	22254-Z0H-U61	.....	2	-----	SJD/A
5	90009-Z0H-003	BOLT, SOCKET, 5X20 .....	3	-----	SJD/A



FR.

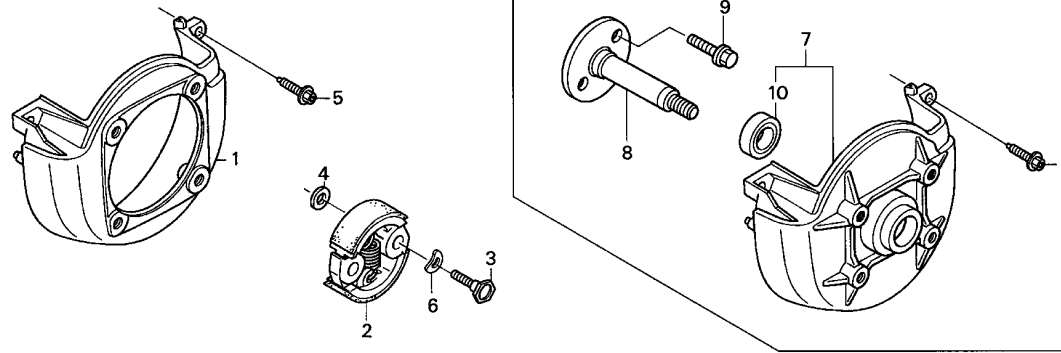

ZOH0-E1200B

Ref. No.	Part No.	Description	Reqd. QTY		Serial No.	Parts catalogue code
			GX	25		
6	22254-ZOH-003	WASHER, WAVE (8MM)	2	-----	-----	HAT,HAT/A,HUT,SAT/A,SATM,SAU/A,SAUT/A,SA2/A,SC2/A,SD/A,SDT/A,SE/A,SEGT SET/A,SJ/A,SJD,SJS,SJS/A,SJT/A,SKN,SKN/A,SUT,SUT/A,TA,TA/A,TA2,TA2/A,TD TD/A,TE,TE/A,TEZ,TEZR,TJ,TJ/A
			2	1017821	-----	SAT,SAU,SAUT,SA2,SC2,SD,SDT,SE,SET,SJ,SJT
	22256-ZOH-U61	WASHER, WAVE (8.2X16)	2	-----	1230202	SJD/A
			2	-----	-----	SAM2,SDM
			2	-----	1230203	SJD/A
7	19610-ZOH-801	COVER COMP., FAN	1	-----	-----	WA,WA/A,WD,WD/A,WE,WE/A,WJ,WJ/A
8	40210-ZOH-800	SHAFT COMP., P.T.O.	1	-----	-----	WA,WA/A,WD,WD/A,WE,WE/A,WJ,WJ/A
9	96001-06022-00	BOLT, FLANGE, 6X22	2	-----	-----	WA,WA/A,WD,WD/A,WE,WE/A,WJ,WJ/A
10	96150-60010-10	BEARING, RADIAL BALL, 6001UU	1	-----	-----	WA,WA/A,WD,WD/A,WE,WE/A,WJ,WJ/A

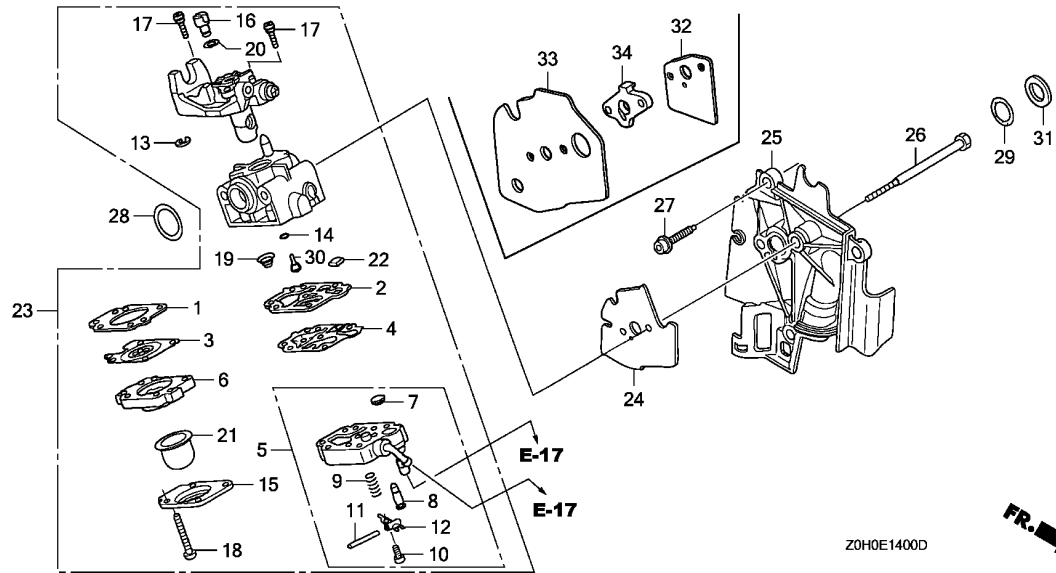

Ref. No.	L.O.N.	(Relative ref. Number) Description	F.R.T.
2		(19,22)	
3111B7		GASKET, CARBURETOR PUMP .....	0.4
5		(4,7)	
3111A0		BODY ASSEMBLY, PUMP .....	0.4
6		(1,3)	
3111A1		BODY, AIR PURGE .....	0.3
8		(9,11,12)	
3111E3		VALVE, INLET NEEDLE .....	0.4
21		3111D5 PUMP, PRIMER .....	0.2
23		3111F3 CARBURETOR .....	0.2
25		(29)	
4141E3		SHROUD, ENGINE .....	0.2
28		3111C7 O-RING, CARBURETOR BODY .....	0.1
30		(14)	
3111C1		JET .....	0.4
34		(24,32,33)	
4141E7		SPACER, SHROUD .....	0.2

Ref. No.	Part No.	Description	Reqd. QTY	Serial No.	Parts catalogue code
			GX 25		
1	16010-ZM3-004	GASKET, METERING DIAPHRAGM ..	1		
2	16011-Z0H-003	GASKET, PUMP .....	1		HAT, SAT, SAU, SAUT, SA2, SC2, SD, SDT, SE, SET, SJ, SJD, SJS, SJT, SKN, SUT, TA, TA2, TD, TE, TJ, WA, WD, WE, WJ
		(CARBURETOR NO.)	1		WYB 10 WD/A, WJ/A
		///	1		WYB 11 SKN/A, TD/A, TJ/A
		///	1		WYB 12A WA/A, WE/A
		///	1		WYB 19A TEZ, TEZR
		///	1		WYB 6C HAT/A, SAM2, SAT/A, SA2/A, SC2/A, SE/A, SEGT, SET/A
		///	1		WYB 7B SATM, SAU/A, SAUT/A, SUT/A
		///	1		WYB 8 SD/A, SDM, SDT/A, SJ/A, SJD/A, SJS/A, SJT/A
		///	1		WYB 9A TA/A, TA2/A, TE/A
16011-Z0H-013		.....	1		HUT
		(CARBURETOR NO.)	1		WYB 10A ..... WD/A, WJ/A
		///	1		WYB 11A ..... SKN/A, TD/A, TJ/A
		///	1		WYB 12B ..... WA/A, WE/A
		///	1		WYB 19B ..... TEZ, TEZR
		///	1		WYB 6D ..... HAT/A, SAM2, SAT/A, SA2/A, SC2/A, SE/A, SEGT, SET/A
		///	1		WYB 7C ..... SATM, SAU/A, SAUT/A, SUT/A
		///	1		WYB 8A ..... SD/A, SDM, SDT/A, SJ/A, SJD/A, SJS/A, SJT/A
		///	1		WYB 9B ..... TA/A, TA2/A, TE/A
3	16013-Z0H-003	DIAPHRAGM ASSY., METERING ...	1		
4	16014-ZM3-004	DIAPHRAGM, PUMP .....	1		



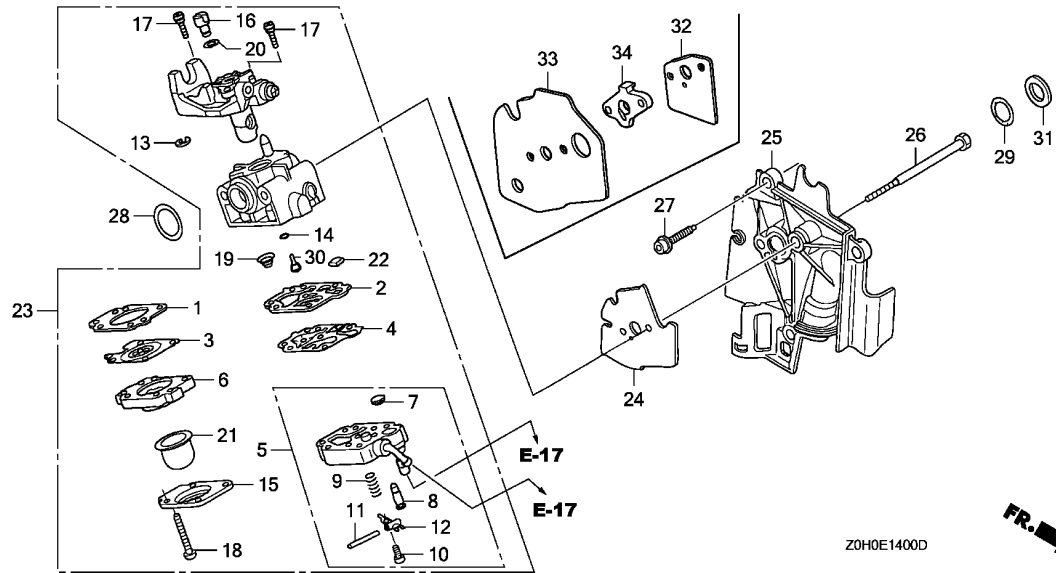

2

Ref. No.	Part No.	Description	Reqd. QTY		Serial No.	Parts catalogue code
			GX	25		
5	16015-Z0H-003	BODY ASSY., PUMP .....	1	-----	HAT,SAT,SAU,SAUT,SA2,SC2,SD,SDT,SE,SET,SJ,SJD,SJS,SJT,SKN,SUT,TA,TA2,TD TE,TJ,WA,WD,WE,WJ	
		(CARBURETOR NO.)	1	-----	WYB 10 WD/A,WJ/A	
		///	1	-----	WYB 11 SKN/A,TD/A,TJ/A	
		///	1	-----	WYB 12A WA/A,WE/A	
		///	1	-----	WYB 19A TEZ,TEZR	
		///	1	-----	WYB 6C HAT/A,SAM2,SAT/A,SA2/A,SC2/A,SE/A,SEGT,SET/A	
		///	1	-----	WYB 7B SATM,SAU/A,SAUT/A,SUT/A	
		///	1	-----	WYB 8 SD/A,SDM,SDT/A,SJ/A,SJD/A,SJS/A,SJT/A	
		///	1	-----	WYB 9A TA/A,TA2/A,TE/A	
	16015-Z0H-013	.....	1	-----	HUT	
		(CARBURETOR NO.)	1	-----	WYB 10A ----- WD/A,WJ/A	
		///	1	-----	WYB 11A ----- SKN/A,TD/A,TJ/A	
		///	1	-----	WYB 12B ----- WA/A,WE/A	
		///	1	-----	WYB 19B ----- TEZ,TEZR	
		///	1	-----	WYB 6D ----- HAT/A,SAM2,SAT/A,SA2/A,SC2/A,SE/A,SEGT,SET/A	
		///	1	-----	WYB 7C ----- SATM,SAU/A,SAUT/A,SUT/A	
		///	1	-----	WYB 8A ----- SD/A,SDM,SDT/A,SJ/A,SJD/A,SJS/A,SJT/A	
		///	1	-----	WYB 9B ----- TA/A,TA2/A,TE/A	
6	16017-ZM3-004	BODY ASSY., AIR PURGE .....	1	-----		
7	16018-ZM3-802	SCREEN, INLET .....	1	-----		
8	16019-ZM3-004	VALVE, INLET NEEDLE .....	1	-----		
9	16020-ZM3-004	SPRING, METERING LEVER .....	1	-----		
10	16021-ZM3-004	SCREW, METERING LEVER PIN ...	1	-----		
11	16022-ZM3-004	PIN, METERING LEVER .....	1	-----	HAT,SAT,SAU,SAUT,SA2,SC2,SD,SDT,SE,SET,SJ,SJD,SJS,SJT,SKN,SUT,TA,TA2,TD TE,TJ,WA,WD,WE,WJ	

Ref. No.	Part No.	Description	Reqd. QTY		Serial No.	Parts catalogue code
			GX	25		
11)	16022-ZM3-014	PIN, METERING LEVER .....	1			HAT/A,HUT,SAM2,SAT/A,SATM,SAU/A,SAUT/A,SA2/A,SC2/A,SD/A,SDM,SDT/A,SE/A SEGT,SET/A,SJ/A,SJD/A,SJS/A,SJT/A,SKN/A,SUT/A,TA/A,TA2/A,TD/A,TE/A,TEZ TEZR,TJ/A,WA/A,WD/A,WE/A,WJ/A
12	16023-ZM3-004	LEVER, METERING .....	1			
13	16024-ZOH-003	RING, RETAINING .....	1			
14	16025-ZM3-004	O-RING .....	1			
15	16026-ZM3-004	COVER, PRIMER PUMP .....	1			
16	16027-ZM3-004	SWIVEL .....	1			
17	16028-ZM3-004	SCREW, THROTTLE COLLAR .....	2			
18	16029-ZM3-004	SCREW, PUMP COVER .....	4			
19	16030-ZM3-004	SPRING, PUMP .....	1			
20	16031-ZM3-004	WASHER .....	1			
21	16032-ZM3-004	PUMP, PRIMER .....	1			
22	16035-ZM3-802	FILTER, FUEL INLET .....	1			
23	16100-ZOH-801	CARBURETOR ASSY. (WYB 7B) ...	1	-----	1000490	SD,SDT,SE,SET,SJ,SJT
	16100-ZOH-831	CARBURETOR ASSY. (WYB 10) ...	1	-----		WD,WE,WJ
			1	-----	1200242	WE/A
			1	-----	1242840	WD/A,WJ/A
	16100-ZOH-841	CARBURETOR ASSY. (WYB 12) ...	1	-----		WA
			1	-----	1220917	WA/A
			1	1200243	1220917	WE/A
	16100-ZOH-802	CARBURETOR ASSY. (WYB 7B) ...	1	-----		SAU,SAUT,SUT
			1	-----	1218410	SAU/A,SAUT/A,SUT/A
	16100-ZOH-812	CARBURETOR ASSY. (WYB 8) ....	1	-----		SJD,SJS
			1	1000491		SD,SDT,SE,SET,SJ,SJT
			1	-----	1200242	SE/A,SET/A
			1	-----	1220677	SD/A,SDT/A,SJ/A,SJD/A,SJS/A,SJT/A
	16100-ZOH-822	CARBURETOR ASSY. (WYB 9) ....	1	-----		TA,TA2
			1	-----	1230267	TA/A,TA2/A
			1	1200243	1230267	TE/A
	16100-ZOH-832	CARBURETOR ASSY. (WYB 10) ...	1	-----	1242841	WD/A,WJ/A
	16100-ZOH-842	CARBURETOR ASSY. (WYB 12) ...	1	-----	1220918	WA/A,WE/A
	16100-ZOH-852	CARBURETOR ASSY. (WYB 11) ...	1	-----		SKN,TD,TE,TJ
			1	-----	1200242	TE/A
			1	-----	1220560	SKN/A,TD/A,TJ/A
	16100-ZOH-013	CARBURETOR ASSY. (WYB 6B) ...	1	-----		HAT,SAT,SA2,SC2
			1	-----	1200659	HAT/A
			1	-----	1218054	SAT/A,SA2/A,SC2/A
			1	1200243	1218054	SE/A,SET/A
	16100-ZOH-803	CARBURETOR ASSY. (WYB 7B) ...	1	-----		1383367 SATM
			1	1218411	1383367	SAU/A,SAUT/A,SUT/A
	16100-ZOH-813	CARBURETOR ASSY. (WYB 8) ....	1	-----		1381296 SDM
			1	1220678	1381296	SD/A,SDT/A,SJ/A,SJD/A,SJS/A,SJT/A
	16100-ZOH-823	CARBURETOR ASSY. (WYB 9) ....	1	-----	1230268	TA/A,TA2/A,TE/A
	16100-ZOH-833	CARBURETOR ASSY. (WYB 10A) ..	1	-----	1381775	WD/A,WJ/A
	16100-ZOH-843	CARBURETOR ASSY. (WYB 12A) ..	1	-----	1277864	1384966 WA/A,WE/A
	16100-ZOH-853	CARBURETOR ASSY. (WYB 11) ...	1	-----	1220561	1439849 SKN/A,TD/A,TJ/A
	16100-ZOH-023	CARBURETOR ASSY. (WYB 6B) ...	1	-----		1282950 SAM2,SEGT
			1	1200660	1213064	HAT/A
			1	1218055	1282950	SAT/A,SA2/A,SC2/A,SE/A,SET/A
	16100-ZOH-804	CARBURETOR ASSY. (WYB 7C) ...	1	-----		HUT
			1	1383368		SATM,SAU/A,SAUT/A,SUT/A
	16100-ZOH-814	CARBURETOR ASSY. (WYB 8A) ...	1	-----	1381297	SD/A,SDM,SDT/A,SJ/A,SJD/A,SJS/A,SJT/A
	16100-ZOH-824	CARBURETOR ASSY. (WYB 9A) ...	1	-----	1378976	1383817 TA/A,TA2/A,TE/A
	16100-ZOH-844	CARBURETOR ASSY. (WYB 12B) ..	1	-----	1384967	WA/A,WE/A
	16100-ZOH-854	CARBURETOR ASSY. (WYB 11A) ..	1	-----	1439850	SKN/A,TD/A,TJ/A

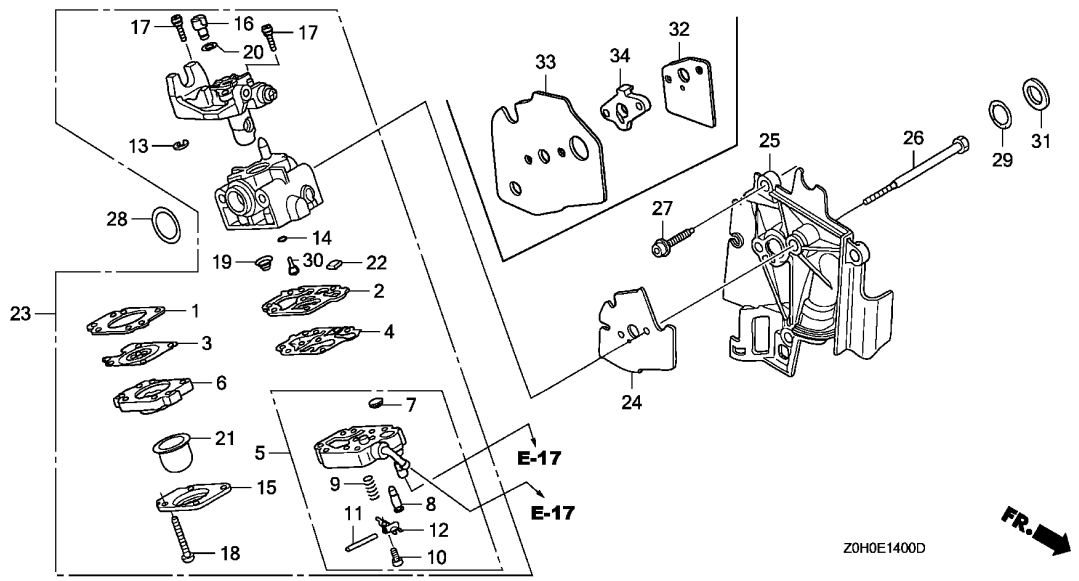

Ref. No.	Part No.	Description	Reqd. QTY		Serial No.	Parts catalogue code
			GX	25		
23)	16100-Z0H-033	CARBURETOR ASSY. (WYB 6C) ...	1	1	1213065 1217011 HAT/A	
	16100-Z0H-825	CARBURETOR ASSY. (WYB 9B) ...	1	1	1282951 1382011 SAM2,SAT/A,SA2/A,SC2/A,SE/A,SEGT,SET/A	
	16100-Z0H-861	CARBURETOR ASSY. (WYB 19A) ...	1	1	1383818 ----- TA/A,TA2/A,TE/A	
	16100-Z0H-043	CARBURETOR ASSY. (WYB 6D) ...	1	1	----- 1001329 TEZ,TEZR	
			1	1	1217012 ----- HAT/A	
	16100-Z0H-862	CARBURETOR ASSY. (WYB 19B) ..	1	1	1382012 ----- SAM2,SAT/A,SA2/A,SC2/A,SE/A,SEGT,SET/A	
	16100-Z0H-862	CARBURETOR ASSY. (WYB 19B) ..	1	1	1001330 ----- TEZ,TEZR	
24	16221-Z0H-000	PACKING, CARBURETOR .....	1	1	----- SAT,SAT/A,SATM,SAU,SAU/A,SAUT,SAUT/A,SA2,SA2/A,SC2,SC2/A,SD,SD/A,SDT,SDT/A,SE,SE/A,SEGT,SET,SET/A,SJ,SJ/A,SJD,SJS,SJS/A,SJT,SJT/A,SKN,SKN/A,SUT,SUT/A,TA,TA/A,TA2,TA2/A,TD,TD/A,TE,TE/A,TEZ,TEZR,TJ,TJ/A	
			1	1	----- 1230202 SJD/A	
	16221-Z0H-V00	.....	1	1	----- HAT,HAT/A,HUT	
25	19631-Z0H-000	SHROUD .....	1	1		
26	90014-Z0H-003	BOLT, 5X53 .....	2	2	----- HAT,HAT/A,HUT,SAT,SAT/A,SATM,SAU,SAU/A,SAUT,SAUT/A,SA2,SA2/A,SC2,SC2/A,SD,SD/A,SDT,SDT/A,SE,SE/A,SEGT,SET,SET/A,SJ,SJ/A,SJD,SJS,SJS/A,SJT,SJT/A,SKN,SKN/A,SUT,SUT/A,TA,TA/A,TA2,TA2/A,TD,TD/A,TE,TE/A,TEZ,TEZR,TJ,TJ/A	
			2	2	----- 1230202 SJD/A	
	90014-Z0H-801	BOLT, 5X59 .....	2	2	----- SAM2,SDM,WA,WA/A,WD,WD/A,WE,WE/A,WJ,WJ/A	
			2	2	1230203 ----- SJD/A	
27	90018-Z0H-003	BOLT, SOCKET, 5X16 .....	3	3		
28	91301-ZM3-000	O-RING, 14.8X2.4 .....	1	1		
29	91308-Z0H-003	O-RING, 12.3X2.4 .....	1	1		
30	99101-ZM5-0330	JET (#33) .....	(1)	(1)	----- SATM,SAU,SAU/A,SAUT,SAUT/A,SJD,SJD/A,SKN,SKN/A,SUT,SUT/A	
		(CARBURETOR NO.)	(1)	(1)	----- WYB 7B SD,SDT,SE,SET,SJ,SJT	
	99101-ZM5-0340	JET (#34) .....	1	1	----- SJD,SJD/A,SKN,SKN/A	
		(CARBURETOR NO.)	(1)	(1)	----- SATM,SAU,SAU/A,SAUT,SAUT/A,SUT,SUT/A	
			(1)	(1)	----- WYB 7B SD,SDT,SE,SET,SJ,SJT	

Ref. No.	Part No.	Description	Reqd. QTY		Serial No.	Parts catalogue code
			GX	25		
30)	99101-ZM5-0350	JET (#35) .....	1	-----	-----	HUT,SATM,SAU,SAU/A,SAUT,SAUT/A,SUT,SUT/A
		(CARBURETOR NO.)	1	-----	WYB 7B	SD,SDT,SE,SET,SJ,SJT
	99101-Z0H-0320	JET (#32) .....	(1)	-----	-----	HAT,HAT/A,SAM2,SAT,SAT/A,SA2,SA2/A,SC2,SC2/A,SD/A,SDM,SDT/A,SE/A,SEGT
		(CARBURETOR NO.)	(1)	WYB 8	-----	SET/A,SJ/A,SJD,SJD/A,SJS,SJS/A,SJT/A,SKN,SKN/A,TA,TA/A,TA2,TA2/A,TD,TD/A
	99101-ZM5-0330	JET (#33) .....	(1)	-----	-----	TE,TE/A,TEZ,TEZR,TJ,TJ/A,WA,WA/A,WD,WD/A,WE,WE/A,WJ,WJ/A
		(CARBURETOR NO.)	(1)	WYB 8	-----	SD,SDT,SE,SET,SJ,SJT
	99101-ZM5-0340	JET (#34) .....	1	-----	-----	HAT,HAT/A,HUT,SAM2,SAT,SAT/A,SA2,SA2/A,SC2,SC2/A,SD/A,SDM,SDT/A,SE/A,SEGT
		(CARBURETOR NO.)	(1)	WYB 8	-----	SET/A,SJ/A,SJS,SJS/A,SJT/A,TA,TA/A,TA2,TA2/A,TD,TD/A,TE,TE/A,TEZ,TEZR,TJ
		(CARBURETOR NO.)	1	WYB 8	-----	TJ/A,WA,WA/A,WD,WD/A,WE,WE/A,WJ,WJ/A
		(CARBURETOR NO.)	(1)	-----	-----	SD,SDT,SE,SET,SJ,SJT
		(CARBURETOR NO.)	(1)	-----	-----	HUT
31	90401-Z0H-000	WASHER .....	1	-----	-----	SJD,SJS,SKN,SUT,TA,TA2,TD,TE,TJ,WA,WD,WE,WJ
			1	1001494	-----	SAT,SAU,SAUT,SA2,SC2,SD,SDT,SE,SET,SJ,SJT
			1	1208427	-----	SAT/A,SAU/A,SAUT/A,SA2/A,SC2/A,SD/A,SDT/A,SE/A,SET/A,SJ/A,SJD/A,SJS/A
			1	1220677	-----	SJT/A,SKN/A,SUT/A,TA/A,TA2/A,TD/A,TE/A,TJ/A
			1	-----	-----	WA/A,WD/A,WE/A,WJ/A
32	16221-ZM3-000	PACKING, CARBURETOR .....	1	-----	-----	SAM2,SDM,WA,WA/A,WD,WD/A,WE,WE/A,WJ,WJ/A
			1	1230203	-----	SJD/A
33	16222-Z0H-800	PACKING, SHROUD .....	1	-----	-----	SAM2,SDM,WA,WA/A,WD,WD/A,WE,WE/A,WJ,WJ/A
			1	1230203	-----	SJD/A
34	19632-Z0H-800	SPACER, SHROUD .....	1	-----	-----	SAM2,SDM,WA,WA/A,WD,WD/A,WE,WE/A,WJ,WJ/A
			1	1230203	-----	SJD/A





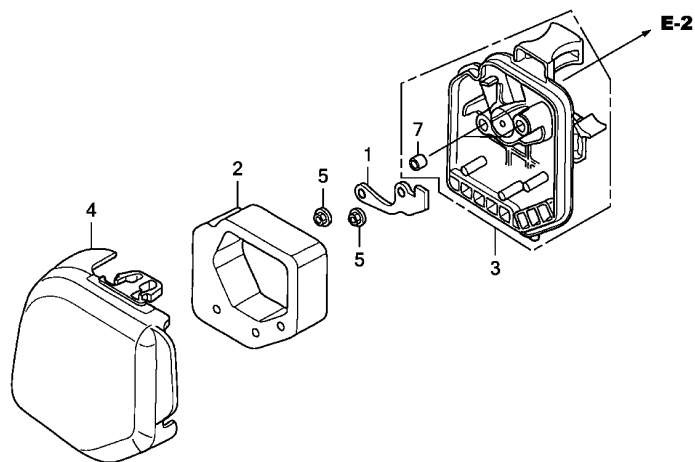

Z0H0E1500C



Ref. No.	L.O.N.	(Relative ref. Number) Description	F.R.T.
2	3121B8	ELEMENT, AIR CLEANER .....	0.1
3	3121A5	CASE, AIR CLEANER .....	0.1
4	3121B1	COVER, AIR CLEANER .....	0.1

Ref. No.	Part No.	Description	Reqd. QTY		Serial No.	Parts catalogue code
				GX 25		
1	17204-Z0H-000	PLATE, OIL TRAP .....	1	-----	-----	HAT,HAT/A,HUT,SAM2,SAT,SAT/A,SATM,SAU,SAU/A,SAUT,SAUT/A,SA2,SA2/A,SC2,SC2/A,SD,SD/A,SDM,SDT,SDT/A,SE,SE/A,SEGT,SET,SET/A,SJ,SJ/A,SJD,SJD/A,SJS,SJS/A,SJT,SJT/A,SUT,SUT/A,WA,WA/A,WD,WD/A,WE,WE/A,WJ,WJ/A
2	17211-Z0H-000	ELEMENT, AIR CLEANER .....	1	-----	-----	HAT,SAM2,SAT,SAT/A,SATM,SAU,SAU/A,SAUT,SAUT/A,SA2,SA2/A,SC2,SC2/A,SD,SD/A,SDM,SDT,SDT/A,SE,SE/A,SEGT,SET,SET/A,SJ,SJ/A,SJD,SJD/A,SJS,SJS/A,SJT,SJT/A,SUT,SUT/A,WA,WA/A,WD,WD/A,WE,WE/A,WJ,WJ/A
3	17220-Z0H-000	CASE COMP., AIR CLEANER .....	1	-----	-----	SAM2,SAT,SAT/A,SATM,SAU,SAU/A,SAUT,SAUT/A,SA2,SA2/A,SC2,SC2/A,SD,SD/A,SDM,SDT,SDT/A,SE,SE/A,SEGT,SET,SET/A,SJ,SJ/A,SJD,SJD/A,SJS,SJS/A,SJT,SJT/A,SUT,SUT/A,WA,WA/A,WD,WD/A,WE,WE/A,WJ,WJ/A
4	17231-Z0H-000	COVER, AIR CLEANER .....	1	-----	-----	SAM2,SAT,SAT/A,SATM,SAU,SAU/A,SAUT,SAUT/A,SA2,SA2/A,SC2,SC2/A,SD,SD/A,SDM,SDT,SDT/A,SE,SE/A,SEGT,SET,SET/A,SJ,SJ/A,SJD,SJD/A,SJS,SJS/A,SJT,SJT/A,SUT,SUT/A,WA,WA/A,WD,WD/A,WE,WE/A,WJ,WJ/A
5	94050-05000	NUT, FLANGE, 5MM .....	2	-----	-----	HAT,HAT/A,HUT,SAM2,SAT,SAT/A,SATM,SAU,SAU/A,SAUT,SAUT/A,SA2,SA2/A,SC2,SC2/A,SD,SD/A,SDM,SDT,SDT/A,SE,SE/A,SEGT,SET,SET/A,SJ,SJ/A,SJD,SJD/A,SJS,SJS/A,SJT,SJT/A,SUT,SUT/A,WA,WA/A,WD,WD/A,WE,WE/A,WJ,WJ/A
7	91503-ZM3-000	COLLAR, AIR CLEANER .....	2	-----	-----	SAM2,SAT,SAT/A,SATM,SAU,SAU/A,SAUT,SAUT/A,SA2,SA2/A,SC2,SC2/A,SD,SD/A,SDM,SDT,SDT/A,SE,SE/A,SEGT,SET,SET/A,SJ,SJ/A,SJD,SJD/A,SJS,SJS/A,SJT,SJT/A,SUT,SUT/A,WA,WA/A,WD,WD/A,WE,WE/A,WJ,WJ/A

**E-15-1**

**AIR CLEANER(2)**

**C15**

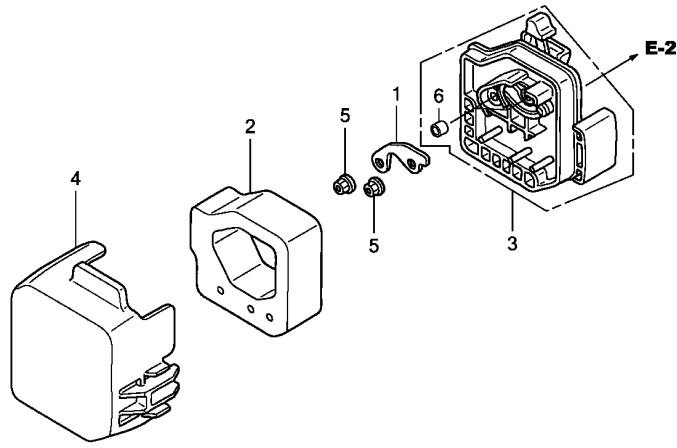

ZOH01501A

Ref. No.	L.O.N.	(Relative ref. Number) Description	F.R.T.
2	3121B8	ELEMENT, AIR CLEANER .....	0.1
3	3121A5	CASE, AIR CLEANER .....	0.1
4	3121B1	COVER, AIR CLEANER .....	0.1

Ref. No.	Part No.	Description	Reqd. QTY	Serial No.	Parts catalogue code
			GX 25		
1	17204-ZOH-800	PLATE, OIL TRAP .....	1	-----	SKN,SKN/A,TA,TA/A,TA2,TA2/A,TD,TD/A,TE,TE/A,TEZ,TEZR,TJ,TJ/A
2	17211-ZOH-800	ELEMENT, AIR CLEANER .....	1	-----	SKN,SKN/A,TA,TA/A,TA2,TA2/A,TD,TD/A,TE,TE/A,TEZ,TEZR,TJ,TJ/A
3	17220-ZOH-801	CASE COMP., AIR CLEANER .....	1	-----	SKN,TA,TA2,TD,TE,TJ
	17220-ZOH-802	.....	1	1271699	SKN/A,TA/A,TA2/A,TD/A,TE/A,TJ/A
	17220-ZOH-810	.....	1	1271700	SKN/A,TA/A,TA2/A,TD/A,TE/A,TJ/A
4	17231-ZOH-800	COVER, AIR CLEANER .....	1	-----	TEZ,TEZR
	17231-ZOH-801	.....	1	-----	SKN,TA,TA2,TD,TE,TJ
	17231-ZOH-810	.....	1	1271699	SKN/A,TA/A,TA2/A,TD/A,TE/A,TJ/A
	17231-ZOH-810	.....	1	1271700	SKN/A,TA/A,TA2/A,TD/A,TE/A,TJ/A
5	94050-05000	NUT, FLANGE, 5MM .....	2	-----	TEZ,TEZR
6	91503-ZM3-000	COLLAR, AIR CLEANER .....	2	-----	SKN,SKN/A,TA,TA/A,TA2,TA2/A,TD,TD/A,TE,TE/A,TEZ,TEZR,TJ,TJ/A

**2**

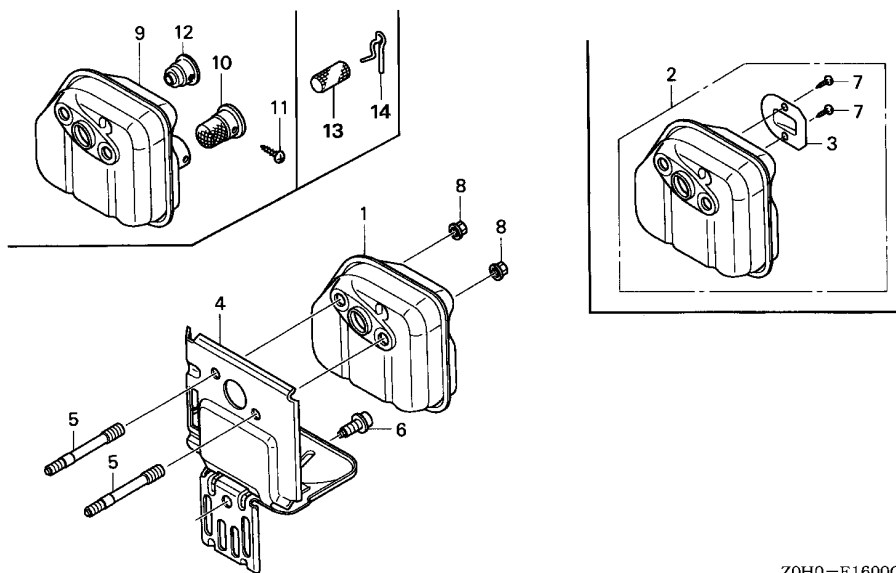

ZOH0-E1600C

Ref. No.	L.O.N.	(Relative ref. Number) Description	F.R.T.
1	(2,9)		
3131C5		MUFFLER, EXHAUST .....	0.1
4	3131B6	GUIDE, AIR EXHAUST .....	0.1
10	(3,13)		
3131A1		ARRESTER, SPARK .....	0.1

Ref. No.	Part No.	Description	Reqd. QTY	Serial No.	Parts catalogue code
			GX 25		
1	18310-ZOH-000	MUFFLER COMP. ....	1	-----	SD,SD/A,SDM,SDT,SDT/A,SE,SE/A,SEGT,SET,SET/A,SJ,SJ/A,SJD,SJD/A,SJS,SJS/A SJT,SJT/A,SKN,SKN/A,WD,WD/A,WE,WE/A,WJ,WJ/A
2	18310-ZOH-800	MUFFLER COMP. ....	1	-----	HAT,HAT/A,HUT,SAM2,SAT,SAT/A,SAU,SAU/A,SAUT,SAUT/A,SA2,SA2/A,SC2,SC2/A SUT,SUT/A,WA,WA/A WD,WD/A,WJ,WJ/A
3	18350-ZOH-800	ARRESTER COMP., SPARK .....	(1)	-----	HAT,HAT/A,HUT,SAM2,SAT,SAT/A,SAU,SAU/A,SAUT,SAUT/A,SA2,SA2/A,SC2,SC2/A SUT,SUT/A,WA,WA/A WD,WD/A,WJ,WJ/A
4	18515-ZOH-000	GUIDE, AIR EX. ....	(1)	-----	HAT,HAT/A,HUT,SAM2,SAT,SAT/A,SATM,SAU,SAU/A,SAUT,SAUT/A,SA2,SA2/A,SC2 SC2/A,SD,SD/A,SDM,SDT,SDT/A,SE,SE/A,SEGT,SET,SET/A,SJ,SJ/A,SJD,SJD/A,SJS SJS/A,SJT,SJT/A,SKN,SKN/A,SUT,SUT/A,TA,TA/A,TA2,TA2/A,TD,TD/A,TE,TE/A,TJ TJ/A,WA,WA/A,WD,WD/A,WE,WE/A,WJ,WJ/A
5	18510-ZOH-800 90001-ZOH-003	GUIDE COMP., AIR EX. .... BOLT, STUD, 2.5X42 .....	1 2	-----	TEZ,TEZR
6	90011-ZOH-003	BOLT, SOCKET, 5X10(CT) .....	1	-----	
7	90055-ZE1-000	SCREW, TAPPING, 4X6 .....	2	-----	HAT,HAT/A,HUT,SAM2,SAT,SAT/A,SAU,SAU/A,SAUT,SAUT/A,SA2,SA2/A,SC2,SC2/A SUT,SUT/A,WA,WA/A WD,WD/A,WJ,WJ/A
8	90136-SM4-901	NUT, SELF-LOCK, 5MM .....	(2)	-----	
9	18310-ZOH-820 18310-ZOH-840 18310-ZOH-850	MUFFLER COMP. .... MUFFLER COMP. (ARRESTER) .... MUFFLER COMP. ....	1 (1) 1	-----	SATM,TA,TA/A,TA2,TA2/A,TD,TD/A,TE,TE/A,TJ,TJ/A TA,TA/A,TA2,TA2/A,TD,TD/A,TJ,TJ/A TEZ,TEZR
10	18350-ZOH-820	ARRESTER COMP., SPARK .....	(1)	-----	SATM,TE/A TA,TA/A,TA2,TA2/A,TD,TD/A,TJ,TJ/A
11	93901-22010	SCREW, TAPPING, 3X6 .....	1	-----	SATM,TA,TA/A,TA2,TA2/A,TD,TD/A,TE,TE/A,TJ,TJ/A
12	18366-ZOH-820	FLANGE, BAFFLE .....	1	-----	SATM,TA,TA/A,TA2,TA2/A,TD,TD/A,TE,TE/A,TJ,TJ/A
13	18354-ZOH-800	FILTER, EXHAUST .....	1	-----	TEZ,TEZR
14	94251-06000	PIN, LOCK, 6MM .....	1	-----	TEZ,TEZR

E-17

FUEL TANK

D 1

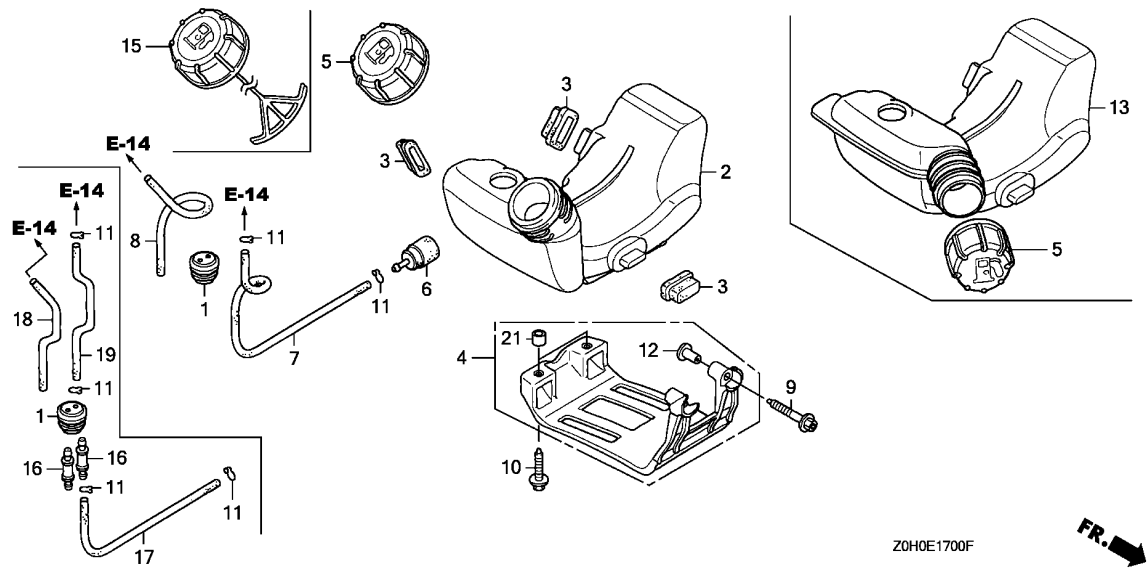

Ref. No.	L.O.N.	(Relative ref. Number) Description	F.R.T.
1	3101J0	GROMMET, FUEL TUBE	0.2
2	3101H7	TANK, FUEL	0.2
4	3101A9	GUARD, TANK	0.1
6	3101A6	FILTER, FUEL	0.2
7	3101F1	TUBE, FUEL TANK	0.2

Ref. No.	Part No.	Description	Reqd. QTY		Serial No.	Parts catalogue code
			GX	25		
1	17504-ZM3-003	GROMMET, FUEL TUBE	1			
2	17511-ZOH-003	TANK, FUEL	1		SAT,SAU,SAUT,SA2,SC2,SD,SDT,SE,SET,SJ,SJD,SJS,SJT,SKN,SUT,WA,WD,WE,WJ	
	17511-ZOH-013		1		HAT	
			1		1211941 HAT/A	
			1		1272524 SAM2,SAT/A,SAU/A,SAUT/A,SA2/A,SC2/A,SD/A,SDM,SDT/A,SE/A,SEGT,SET/A,SJ/A	
			1		SJD/A,SJS/A,SJT/A,SKN/A,SUT/A,WA/A,WD/A,WE/A,WJ/A	
	17511-ZOH-023		1		HUT,SATM	
			1		1211942 HAT/A	
			1		1272525 SAM2,SAT/A,SAU/A,SAUT/A,SA2/A,SC2/A,SD/A,SDM,SDT/A,SE/A,SEGT,SET/A,SJ/A	
			1		SJD/A,SJS/A,SJT/A,SKN/A,SUT/A,WA/A,WD/A,WE/A,WJ/A	
3	17533-ZOH-000	RUBBER, TANK MOUNTING	3			
4	17555-ZOH-010	GUARD, TANK	1		SAT,SAT/A,SATM,SAUT,SAUT/A,SDT,SDT/A,SEGT,SET,SET/A,SJT,SJT/A,SUT,SUT/A	
5	17620-ZM3-043	CAP ASSY., FUEL TANK	1		SAT,SAU,SAUT,SA2,SC2,SD,SDT,SJ,SJD,SJS,SJT,SKN,SUT,TA,TA2,TD,TE,TJ,WA,WD	
			1		WE,WJ	
	17620-ZM3-053		1		SAM2,SAT/A,SATM,SAU/A,SAUT/A,SA2/A,SC2/A,SD/A,SDM,SDT/A,SJ/A,SJD/A,SJS/A	
			1		SJT/A,SKN/A,SUT/A,TA/A,TA2/A,TD/A,TE/A,TEZ,TEZR,TJ/A,WA/A,WD/A,WE/A,WJ/A	
6	17672-ZM3-003	FILTER, FUEL	1		HAT,SAT,SAU,SAUT,SA2,SC2,SD,SDT,SE,SET,SJ,SJD,SJS,SJT,SKN,SUT,TA,TA2,TD	
			1		TE,TJ,WA,WD,WE,WJ	
			1		1211941 HAT/A	
			1		1258242 TA/A,TA2/A,TD/A,TE/A,TJ/A	
			1		1272524 SAM2,SAT/A,SAU/A,SAUT/A,SA2/A,SC2/A,SD/A,SDM,SDT/A,SE/A,SEGT,SET/A,SJ/A	
			1		SJD/A,SJS/A,SJT/A,SKN/A,SUT/A,WA/A,WD/A,WE/A,WJ/A	
	17672-ZOH-003		1		HUT,SATM,TEZ,TEZR	
			1		1211942 HAT/A	
			1		1258243 TA/A,TA2/A,TD/A,TE/A,TJ/A	
			1		1272525 SAM2,SAT/A,SAU/A,SAUT/A,SA2/A,SC2/A,SD/A,SDM,SDT/A,SE/A,SEGT,SET/A,SJ/A	
			1		SJD/A,SJS/A,SJT/A,SKN/A,SUT/A,WA/A,WD/A,WE/A,WJ/A	

2

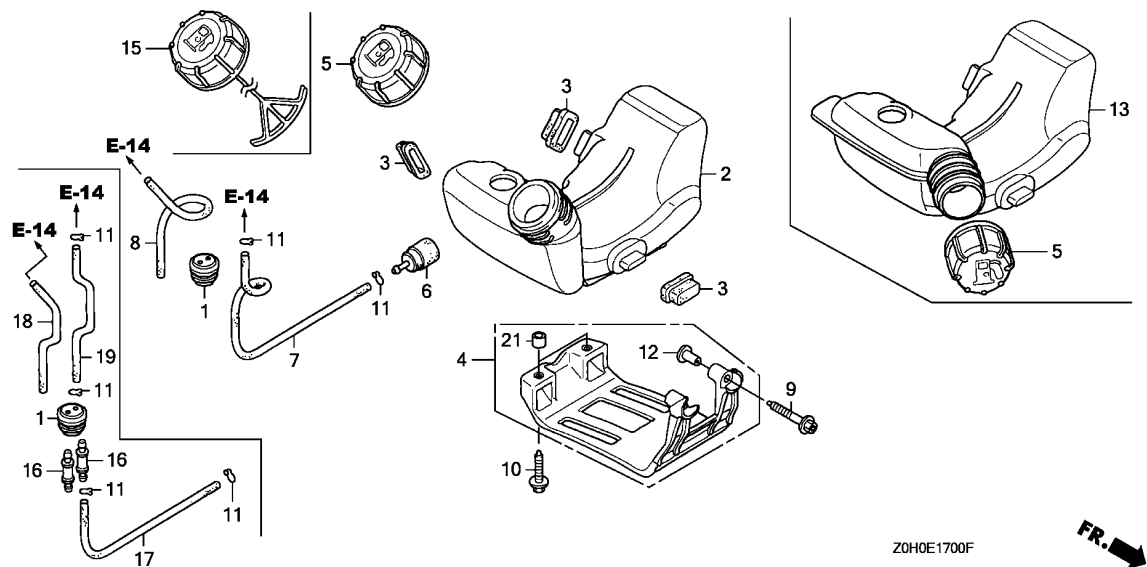

Ref. No.	Part No.	Description	Reqd. QTY		Serial No.	Parts catalogue code
			GX	25		
7	17701-ZOH-003	TUBE, FUEL TANK .....	1	-----	-----	HAT,HAT/A,HUT,SAM2,SAT,SAT/A,SATM,SAU,SAU/A,SAUT,SAUT/A,SA2,SA2/A,SC2,SC2/A,SD,SD/A,SDM,SDT,SDT/A,SE,SE/A,SEGT,SET,SET/A,SJ,SJ/A,SJD,SJD/A,SJS,SJS/A,SJT,SJT/A,SKN,SKN/A,SUT,SUT/A,TA,TA2,TD,TE,TJ,WA,WA/A,WD,WD/A,WE,WE/A,WJ,WJ/A
8	17702-ZOH-003	TUBE, FUEL RETURN .....	1	-----	1258242	TA/A,TA2/A,TD/A,TE/A,TJ/A HAT,HAT/A,HUT,SAM2,SAT,SAT/A,SATM,SAU,SAU/A,SAUT,SAUT/A,SA2,SA2/A,SC2,SC2/A,SD,SD/A,SDM,SDT,SDT/A,SE,SE/A,SEGT,SET,SET/A,SJ,SJ/A,SJD,SJD/A,SJS,SJS/A,SJT,SJT/A,SKN,SKN/A,SUT,SUT/A,TA,TA2,TD,TE,TJ,WA,WA/A,WD,WD/A,WE,WE/A,WJ,WJ/A
9	90010-ZOH-003	BOLT, SOCKET, 5X30 .....	1	-----	1258242	TA/A,TA2/A,TD/A,TE/A,TJ/A
10	90018-ZOH-003	BOLT, SOCKET, 5X16 .....	2	-----	-----	SAT,SAT/A,SATM,SAUT,SAUT/A,SDT,SDT/A,SEGT,SET,SET/A,SJT,SJT/A,SUT,SUT/A
11	91401-ZM3-003	CLIP, TUBE .....	2	-----	-----	HAT,HAT/A,HUT,SAM2,SAT,SAT/A,SATM,SAU,SAU/A,SAUT,SAUT/A,SA2,SA2/A,SC2,SC2/A,SD,SD/A,SDM,SDT,SDT/A,SE,SE/A,SEGT,SET,SET/A,SJ,SJ/A,SJD,SJD/A,SJS,SJS/A,SJT,SJT/A,SKN,SKN/A,SUT,SUT/A,TA,TA2,TD,TE,TJ,WA,WA/A,WD,WD/A,WE,WE/A,WJ,WJ/A
			2	-----	1258242	TA/A,TA2/A,TD/A,TE/A,TJ/A
			4	-----	-----	TEZ,TEZR
			4	-----	1258243	TA/A,TA2/A,TD/A,TE/A,TJ/A
12	91501-ZOH-000	COLLAR, TANK GUARD .....	2	-----	-----	SAT,SAT/A,SATM,SAUT,SAUT/A,SDT,SDT/A,SEGT,SET,SET/A,SJT,SJT/A,SUT,SUT/A
13	17511-ZOH-821	TANK, FUEL .....	1	-----	-----	TA,TA2,TD,TE,TJ
	17511-ZOH-822	.....	1	-----	1258242	TA/A,TA2/A,TD/A,TE/A,TJ/A
	17511-ZOH-823	.....	1	-----	-----	TEZ,TEZR
			1	-----	1258243	TA/A,TA2/A,TD/A,TE/A,TJ/A
15	17620-ZM3-815	CAP ASSY., FUEL TANK .....	1	-----	-----	SE,SET
	17620-ZM3-816	.....	1	-----	-----	HAT,HAT/A,HUT,SE/A,SEGT,SET/A

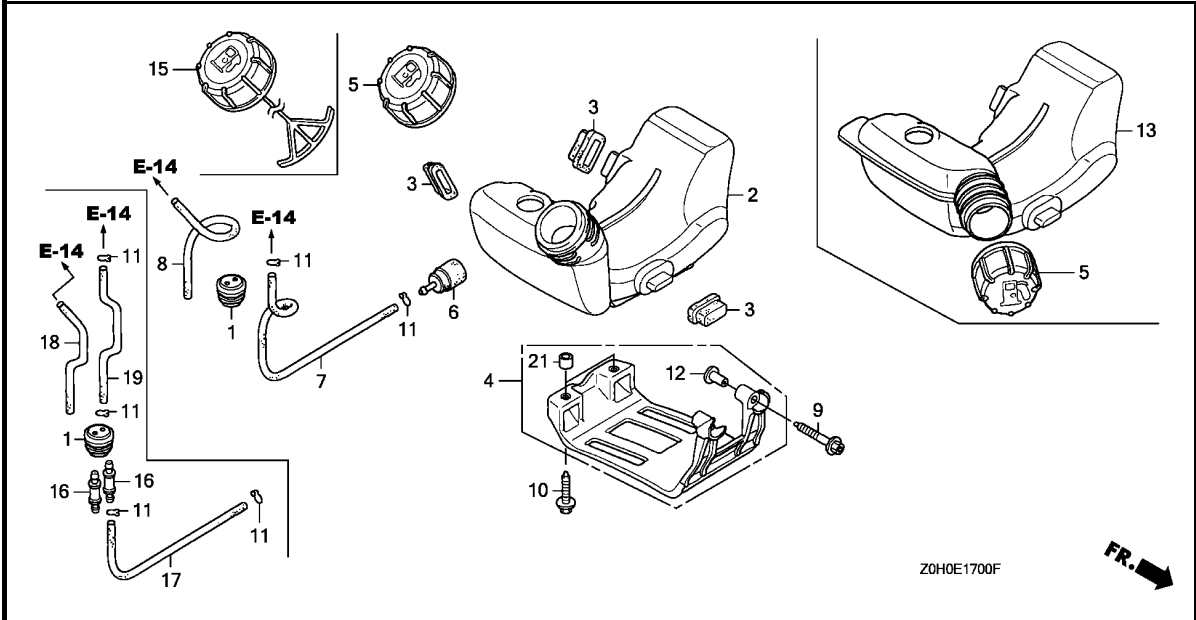

Ref. No.	Part No.	Description	Reqd. QTY		Serial No.	Parts catalogue code
			GX	25		
16	17519-ZM5-003	FITTING .....	2	-----	-----	TEZ,TEZR TA/A,TA2/A,TD/A,TE/A,TJ/A
17	17701-Z0H-820	TUBE, FUEL TANK .....	1	-----	1258243	----- TEZ,TEZR
18	17702-Z0H-820	TUBE, FUEL RETURN .....	1	-----	1258243	----- TA/A,TA2/A,TD/A,TE/A,TJ/A
19	17703-Z0H-820	TUBE A, FUEL .....	1	-----	1258243	----- TEZ,TEZR
21	91506-ZM3-000	COLLAR A, HEAD COVER .....	2	-----	1258243	----- TA/A,TA2/A,TD/A,TE/A,TJ/A SAT,SAT/A,SATM,SAUT,SAUT/A,SDT,SDT/A,SEGT,SET,SET/A,SJT,SJT/A,SUT,SUT/A

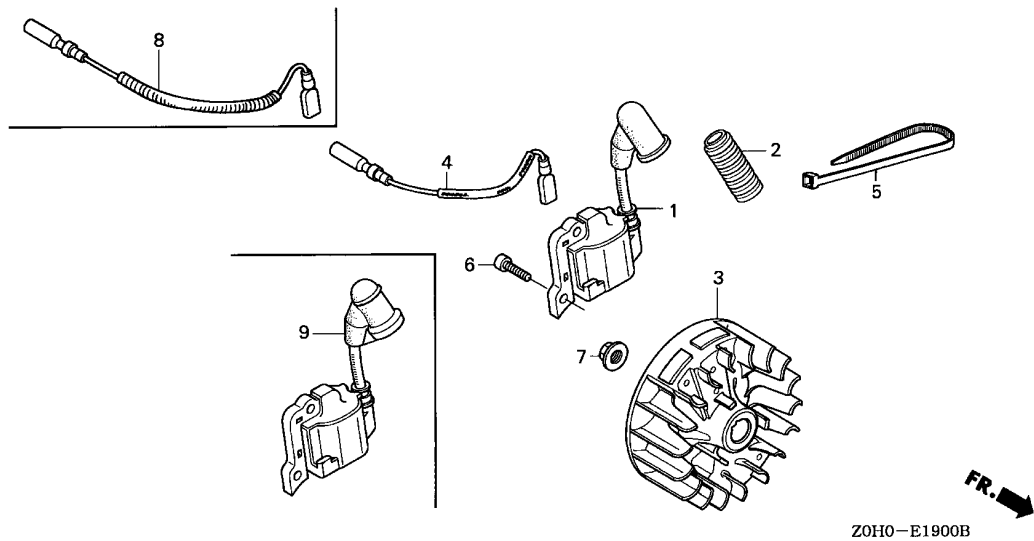

Ref. No.	L.O.N.	(Relative ref. Number) Description	F.R.T.
1		(9)	
1	6141A5	COIL, IGNITION(ONE) .....	0.1
3	2161B5	FLYWHEEL .....	0.3
4		(8)	
	6111B3	CORD, STOP SWITCH .....	0.1

2

Ref. No.	Part No.	Description	Reqd. QTY	Serial No.	Parts catalogue code
			GX 25		
1	30500-ZOH-003	COIL ASSY., IGNITION .....	1	1073685	SAT,SAU,SAUT,SA2,SC2,SD,SDT,SE,SET,SJ,SJS,SJT,SUT,TA,TA2,TD,TE,TJ,WA,WD,WE,WJ
2	30519-ZOH-000	TUBE, CORRUGATE .....	1	1073685	SAT,SAU,SAUT,SA2,SC2,SD,SDT,SE,SET,SJ,SJS,SJT,SUT,TA,TA2,TD,TE,TJ,WA,WD,WE,WJ
3	31110-ZOH-003	FLYWHEEL COMP. ....	1		HAT,HAT/A,HUT,SAM2,SAT,SAT/A,SATM,SAU,SAU/A,SAUT,SAUT/A,SA2,SA2/A,SC2,SC2/A,SD,SD/A,SDM,SDT,SDT/A,SE,SE/A,SEGT,SET,SET/A,SJ,SJ/A,SJD,SJD/A,SJS,SJS/A,SJT,SJT/A,SKN,SKN/A,SUT,SUT/A,TA,TA/A,TA2,TA2/A,TD,TD/A,TE,TE/A,TJ,TJ/A
	31110-ZOH-810	.....	1	1026919	WA,WD,WE,WJ
	31110-ZOH-811	.....	1		WA/A,WD/A,WE/A,WJ/A
			1	1026920	WA,WD,WE,WJ
	31110-ZOH-821	.....	1		TEZ,TEZR
4	32195-ZOH-000	CORD, STOP SWITCH .....	1		HAT,HAT/A,HUT,SAM2,SAT,SAT/A,SATM,SAU,SAU/A,SAUT,SAUT/A,SA2,SA2/A,SC2,SC2/A,SD,SD/A,SDM,SDT,SDT/A,SE,SE/A,SEGT,SET,SET/A,SJ,SJ/A,SJD,SJD/A,SJS,SJS/A,SJT,SJT/A,SKN,SKN/A,SUT,SUT/A,TA,TA/A,TA2,TA2/A,TD,TD/A,TE,TE/A,TJ,TJ/A
	32195-ZOH-810	.....	1		TEZ,TEZR
5	32901-ZOH-000	TIE, CABLE .....	1	1073685	SAT,SAU,SAUT,SA2,SC2,SD,SDT,SE,SET,SJ,SJS,SJT,SUT,TA,TA2,TD,TE,TJ,WA,WD,WE,WJ
6	90012-ZOH-005	BOLT, SOCKET, 4X14 .....	2		
7	90355-427-770	NUT, FLANGE, 7MM .....	1		
8	32195-ZOH-800	CORD, STOP SWITCH .....	1		WA,WA/A,WD,WD/A,WE,WE/A,WJ,WJ/A

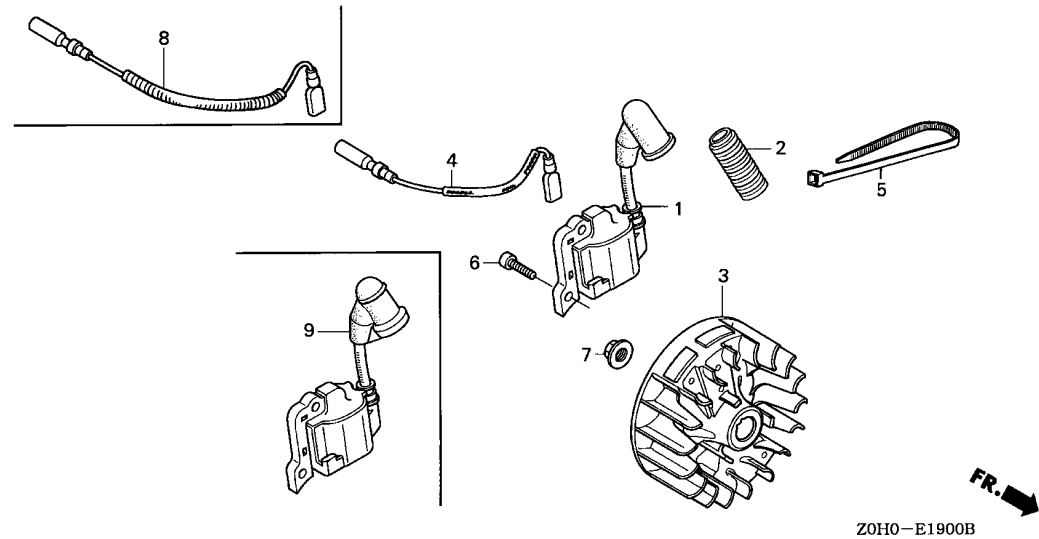

Ref. No.	Part No.	Description	Reqd. QTY		Serial No.	Parts catalogue code
			GX	25		
9	30500-Z0H-013	COIL ASSY., IGNITION .....	1	-----	-----	HAT,SJD,SKN
			1	1073686	-----	SAT,SAU,SAUT,SA2,SC2,SD,SDT,SE,SET,SJ,SJS,SJT,SUT,TA,TA2,TD,TE,TJ,WA,WD WE,WJ
			1	-----	1216120	HAT/A
30500-Z0H-023	.....	.....	1	-----	-----	SAM2,SAT/A,SAU/A,SAUT/A,SA2/A,SC2/A,SD/A,SDM,SDT/A,SE/A,SEGT,SET/A,SJ/A SJD/A,SJS/A,SJT/A,SKN/A,SUT/A,TA/A,TA2/A,TD/A,TE/A,TJ/A,WA/A,WD/A,WE/A WJ/A
			1	-----	1216121	HUT,SATM
			1	-----	1356416	HAT/A
30500-Z0H-801	.....	.....	1	-----	-----	SAM2,SAT/A,SAU/A,SAUT/A,SA2/A,SC2/A,SD/A,SDM,SDT/A,SE/A,SEGT,SET/A,SJ/A SJD/A,SJS/A,SJT/A,SKN/A,SUT/A,TA/A,TA2/A,TD/A,TE/A,TJ/A,WA/A,WD/A,WE/A WJ/A
			1	-----	-----	TEZ,TEZR





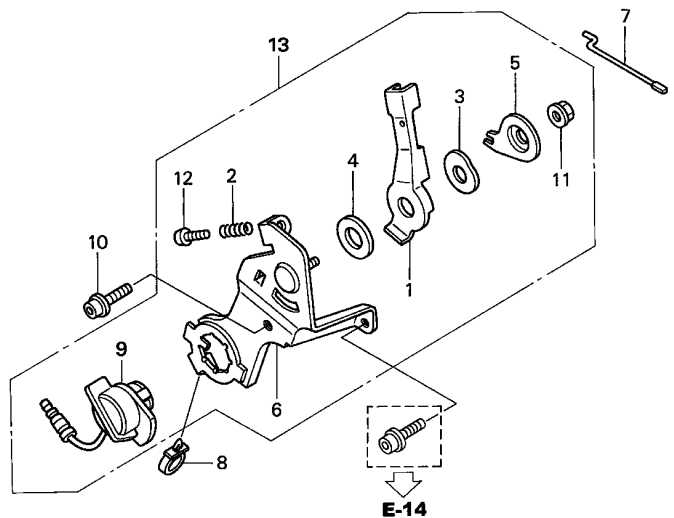

FR. →

Z0H0-E2200B

Ref. No.	L.O.N.	(Relative ref. Number) Description	F.R.T.
1	1161A8	LEVER, CONTROL .....	0.3
6	1161A2	BASE, CONTROL .....	0.3
9	6151D9	SWITCH, ENGINE STOP .....	0.1
13	1161A5	CONTROL, THROTTLE/GOVERNOR ...	0.2

Ref. No.	Part No.	Description	Reqd. QTY	Serial No.	Parts catalogue code
			GX 25		
1	16571-Z0H-800	LEVER, CONTROL .....	1	-----	WA,WA/A,WD,WD/A,WE,WE/A,WJ,WJ/A
2	16571-892-000	SPRING, CONTROL ADJUSTING ...	1	-----	WA,WA/A,WD,WD/A,WE,WE/A,WJ,WJ/A
3	16574-ZE1-000	SPRING, LEVER .....	1	-----	WA,WA/A,WD,WD/A,WE,WE/A,WJ,WJ/A
4	16578-ZE1-000	SPACER, CONTROL LEVER .....	1	-----	WA,WA/A,WD,WD/A,WE,WE/A,WJ,WJ/A
5	16575-ZH8-000	WASHER, CONTROL LEVER .....	1	-----	WA,WA/A,WD,WD/A,WE,WE/A,WJ,WJ/A
6	16580-Z0H-800	BASE COMP., CONTROL .....	1	-----	WA,WA/A,WD,WD/A,WE,WE/A,WJ,WJ/A
7	17841-Z0H-800	ROD, THROTTLE .....	1	-----	WA,WA/A,WD,WD/A,WE,WE/A,WJ,WJ/A
8	30701-883-000	CLIP, HIGH TENSION CORD (8MM)	1	-----	WA,WA/A,WD,WD/A,WE,WE/A,WJ,WJ/A
9	35120-Z0D-V81	SWITCH ASSY., ENGINE STOP ...	1	-----	WA,WA/A,WD,WD/A,WE,WE/A,WJ,WJ/A
10	90011-Z0H-801	BOLT, SOCKET, 5X10 .....	1	-----	WA,WA/A,WD,WD/A,WE,WE/A,WJ,WJ/A
11	90114-SA0-000	NUT, SELF-LOCK, 6MM .....	1	-----	WA,WA/A,WD,WD/A,WE,WE/A,WJ,WJ/A
12	93500-05025-0A	SCREW, PAN, 5X25 .....	1	-----	WA,WA/A,WD,WD/A,WE,WE/A,WJ,WJ/A
13	16500-Z0H-801	CONTROL ASSY. ....	1	-----	WA,WA/A,WD,WD/A,WE,WE/A,WJ,WJ/A

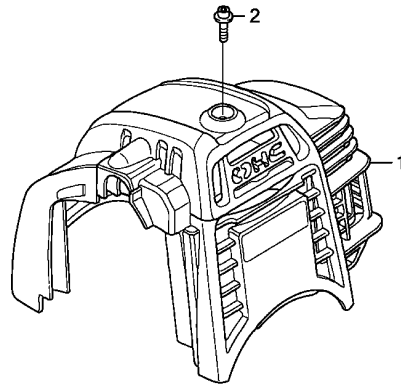

Ref. No.	L.O.N. (Relative ref. Number)	Description	F.R.T.
1	1111D6	COVER, ENGINE TOP .....	0.1

Ref. No.	Part No.	Description	Reqd. QTY	Serial No.	Parts catalogue code
			GX 25		
1	19720-Z0H-000ZB	COVER COMP., TOP	1	-----	SAM2,SAT,SAT/A,SAU,SAU/A,SAUT,SAUT/A,SA2,SA2/A,SC2,SC2/A,SD,SD/A,SDM,SDT SDT/A,SE,SE/A,SET,SET/A,SJ,SJ/A,SJD,SJD/A,SJS,SJS/A,SJT,SJT/A,SKN,SKN/A SUT,SUT/A,WA,WA/A,WD,WD/A,WE,WE/A,WJ,WJ/A
	19720-Z0H-000ZC	*T92*.....STIGA YELLOW	1	-----	SEGT
	19720-Z0H-800ZA	*R280*.....POWER RED	1	-----	SATM,TA,TA/A,TA2,TA2/A,TD,TD/A,TE,TE/A,TJ,TJ/A
	19720-Z0H-810ZA	*R280*.....POWER RED	1	-----	TEZ,TEZR
2	90015-Z0H-003	BOLT, TOP COVER .....	1		



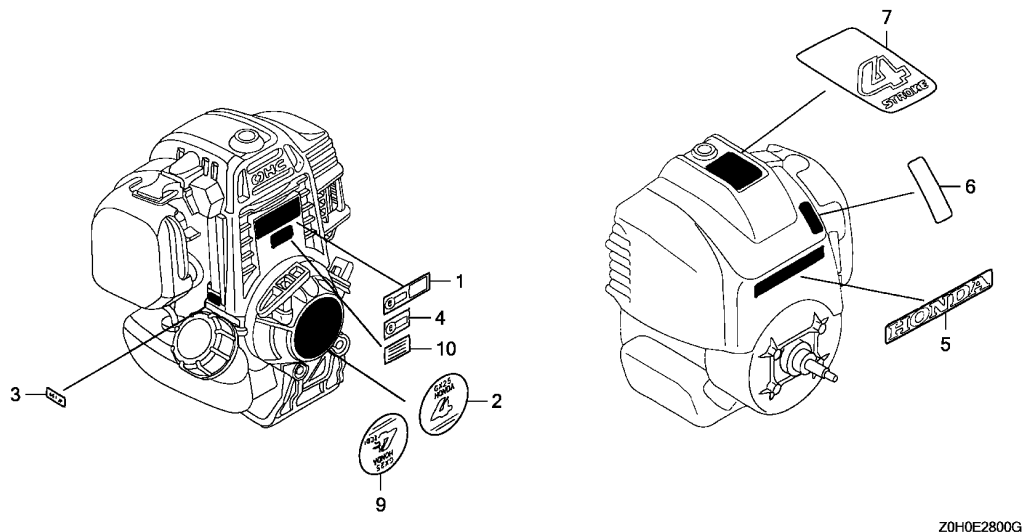

ZOH0E2800G

Ref. L.O.N. (Relative ref. Number) F.R.T.  
No. Description

NO INFORMATION .....

Ref. No.	Part No.	Description	Reqd. QTY	Serial No.	Parts catalogue code
			GX 25		
1	87135-ZOH-000	LABEL, E-SPEC (EPA STANDARD)	1	-----	SJS,TD,TE,TJ,WD,WE,WJ
2	87521-ZOH-000	MARK, EMBLEM .....	1	----- 1023826	SAU,SAUT,SD,SDT,SE,SET,SJ,SJT
					SAM2,SAT,SAT/A,SATM,SAU,SAU/A,SAUT,SAUT/A,SA2,SA2/A,SC2,SC2/A,SD,SD/A,SDM
					SDT,SDT/A,SE,SE/A,SEGT,SET,SET/A,SJ,SJ/A,SJD,SJD/A,SJS,SJS/A,SJT,SJT/A
					SKN,SKN/A,SUT,SUT/A,TA,TA/A,TA2,TA2/A,TD,TD/A,TE,TE/A,TJ,TJ/A,WA,WA/A,WD
					WD/A,WE,WE/A,WJ,WJ/A
	87521-ZOH-800	.....	1	----- 1001329	TEZ
	87521-ZOH-801	.....	1	----- 1001330	TEZ
3	87601-ZOH-800	MARK, TYPE (SJ) .....	1	-----	SJ,SJ/A
	87601-ZOH-810	MARK, TYPE (SJT) .....	1	-----	SJT,SJT/A
	87601-ZOH-820	MARK, TYPE (SC2) .....	1	-----	SC2,SC2/A
	87601-ZOH-830	MARK, TYPE (SE) .....	1	-----	SE,SE/A
	87601-ZOH-840	MARK, TYPE (SET) .....	1	-----	SET,SET/A
	87601-ZOH-850	MARK, TYPE (SA2) .....	1	-----	SA2,SA2/A
	87601-ZOH-860	MARK, TYPE (SAT) .....	1	-----	SAT,SAT/A
	87601-ZOH-870	MARK, TYPE (SAU) .....	1	-----	SAU,SAU/A
	87601-ZOH-880	MARK, TYPE (SAUT) .....	1	-----	SAUT,SAUT/A
	87601-ZOH-890	MARK, TYPE (SD) .....	1	-----	SD,SD/A
	87601-ZOH-900	MARK, TYPE (SDT) .....	1	-----	SDT,SDT/A
	87601-ZOH-700	MARK, TYPE (WJ) .....	1	-----	WJ,WJ/A
	87601-ZOH-710	MARK, TYPE (WA) .....	1	-----	WA,WA/A
	87601-ZOH-720	MARK, TYPE (WE) .....	1	-----	WE,WE/A
	87601-ZOH-730	MARK, TYPE (WD) .....	1	-----	WD,WD/A
	87601-ZOH-740	MARK, TYPE (TJ) .....	1	-----	TJ,TJ/A
	87601-ZOH-750	MARK, TYPE (TA) .....	1	-----	TA,TA/A
	87601-ZOH-760	MARK, TYPE (TE) .....	1	-----	TE,TE/A
	87601-ZOH-770	MARK, TYPE (TD) .....	1	-----	TD,TD/A
	87601-ZOH-780	MARK, TYPE (TA2) .....	1	-----	TA2,TA2/A
	87601-ZOH-940	MARK, TYPE (SJS) .....	1	-----	SJS,SJS/A

Ref. No.	Part No.	Description	Reqd. QTY		Serial No.	Parts catalogue code
			GX	25		
(3)	87601-Z0H-950	MARK, TYPE (SUT) .....	1	-----	-----	SUT,SUT/A
	87601-Z0H-960	MARK, TYPE (SKN) .....	1	-----	-----	SKN,SKN/A
	87601-Z0H-970	MARK, TYPE (SJD) .....	1	-----	-----	SJD,SJD/A
	87601-Z0H-U60	MARK, TYPE (SDM) .....	1	-----	-----	SDM
	87601-Z0H-V10	MARK, TYPE (SEGT) .....	1	-----	-----	SEGT
	87601-Z0H-U70	MARK, TYPE (SAM2) .....	1	-----	-----	SAM2
	87601-Z0H-610	MARK, TYPE (TEZ) .....	1	-----	-----	TEZ
	87601-Z0H-620	MARK, TYPE (TEZR) .....	1	-----	-----	TEZR
	87601-Z0H-V20	MARK, TYPE (SATM) .....	1	-----	-----	SATM
4	87135-ZE2-020	LABEL, E-SPEC (15.5X27.5) ...	1	-----	-----	SATM,SAU/A,SAUT/A,SD/A,SDM,SDT/A,SJ/A,SJD,SJD/A,SJS/A,SJT/A,SKN,SKN/A,SUT
			1	1023827	-----	SUT/A,TD/A,TJ/A,WD/A,WJ/A
			1	1212057	-----	SAU,SAUT,SD,SDT,SE,SET,SJ,SJT
5	87531-Z0H-J00	MARK, HONDA .....	1	-----	1089756	SE/A,SET/A,TE/A,WE/A
	87531-Z0H-000	.....	1	-----	-----	SUT
			1	-----	-----	SAM2,SAT/A,SATM,SAU/A,SAUT/A,SA2/A,SC2/A,SD/A,SDM,SDT/A,SE/A,SET/A,SJ/A
			1	1089757	-----	SJD/A,SJS/A,SJT/A,SUT/A
			1	-----	-----	SAT,SAU,SAUT,SA2,SC2,SD,SDT,SE,SET,SJ,SJD,SJS,SJT,SUT
6	87532-ZM3-G00	MARK, THROTTLE INDICATION ...	1	-----	-----	WA,WA/A,WD,WD/A,WE,WE/A,WJ,WJ/A
7	87660-Z0H-J00	MARK (4-STROKE) .....	1	-----	-----	SUT/A
			1	1090117	-----	SUT
	87660-Z0H-000	.....	1	-----	-----	SAM2,SAT/A,SATM,SAU/A,SAUT/A,SA2/A,SC2/A,SD/A,SDM,SDT/A,SE/A,SEGT,SET/A
			1	-----	-----	SJ/A,SJD/A,SJS/A,SJT/A,SKN/A,WA/A,WD/A,WE/A,WJ/A
			1	1089757	-----	SAT,SAU,SAUT,SA2,SC2,SD,SDT,SE,SET,SJ,SJD,SJS,SJT
9	87521-Z0H-800	MARK, EMBLEM .....	1	-----	1001329	TEZR
	87521-Z0H-801	.....	1	1001330	-----	TEZR
10	87114-ZH7-000	LABEL, WARNING	1	-----	-----	
		(NOT CERTIFIED FOR SALE)	1	1289125	1399372	SD/A,SDM,SDT/A,SJ/A,SJD/A,SJS/A,SJT/A,SKN/A,TD/A,TJ/A,WD/A,WJ/A
	87114-ZH7-810	.....	1	1399373	-----	SD/A,SDM,SDT/A,SJ/A,SJD/A,SJS/A,SJT/A,SKN/A,TD/A,TJ/A,WD/A,WJ/A
			1	1432955	-----	SAU/A,SAUT/A,SUT/A
			1	1470053	-----	SATM



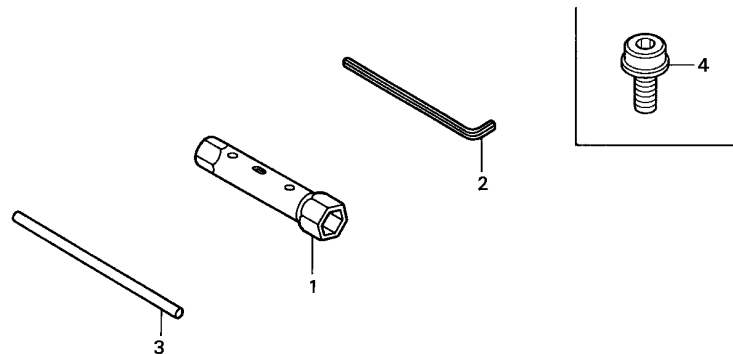

ZOH0-E2900 A

Ref. L.O.N. (Relative ref. Number) F.R.T.  
 No. Description

NO INFORMATION .....

Ref. No.	Part No.	Description	Reqd. QTY		Serial No.	Parts catalogue code
			GX	25		
1	89216-045-010	WRENCH, SPARK PLUG .....	(1)			
2	89221-KW3-000	WRENCH, HEX., 4MM .....	(1)			
3	99005-01000	BAR A, HANDLE .....	(1)			
4	90011-ZOH-811	BOLT, SOCKET, 5X9 .....	1	-----	SUT,SUT/A	
			(1)	-----	HAT,HAT/A,HUT,SAT/A,SATM,SAU/A,SAUT/A,SA2/A,SC2/A,SD/A,SDT/A,SE/A,SEGT SET/A,SJ/A,SJD,SJD/A,SJS/A,SJT/A,SKN,SKN/A,TA/A,TA2/A,TD/A,TE/A,TEZ,TEZR TJ/A	



# PART NO. INDEX

**E 2**

Part Number	Address	Page	Ref.	Part Number	Address	Page	Ref.	Part Number	Address	Page	Ref.	Part Number	Address	Page	Ref.
89000				94251-06000	C16	32	14								
89216-045-010	D10	42	1	94305-40102	C2	18	22								
89221-KW3-000	D10	42	2	95000											
90000				95002-41200-08	C2	18	23								
90001-Z0H-003	C16	32	5	95002-41300-04	C2	18	24								
90009-Z0H-003	C2	18	14	96000											
	C6	22	19												
	C7	23	5	96001-06022-00	C8	24	9								
90010-Z0H-003	C2	18	15	96150-60010-10	C8	24	10								
	D2	34	9	99000											
90011-Z0H-003	C16	32	6												
90011-Z0H-801	D6	38	10	99005-01000	D10	42	3								
90011-Z0H-811	D10	42	4	99101-Z0H-0320	C13	29	30								
90012-Z0H-005	D4	36	6	99101-ZM5-0330	C12	28	30								
90012-ZM3-003	C6	22	10		C13	29	30								
90013-Z0H-004	C2	18	16	99101-ZM5-0340	C12	28	30								
90014-Z0H-003	C12	28	26		C13	29	30								
90014-Z0H-801	C12	28	26	99101-ZM5-0350	C13	29	30								
90015-Z0H-003	D7	39	2												
90017-Z0H-000	C2	18	17												
90018-Z0H-003	C6	22	11												
	C12	28	27												
	D2	34	10												
90019-Z0H-003	C2	18	18												
90043-Z0H-000	C6	22	14												
90055-ZE1-000	C16	32	7												
90114-SAO-000	D6	38	11												
90136-SM4-901	C16	32	8												
90206-ZM3-000	C2	18	19												
90355-427-770	D4	36	7												
90401-Z0H-000	C13	29	31												
91000															
91211-Z0H-003	C3	19	5												
91212-Z0H-003	C3	19	6												
91301-ZM3-000	C12	28	28												
91308-Z0H-003	C12	28	29												
91401-ZM3-003	D2	34	11												
91501-Z0H-000	D2	34	12												
91503-ZM3-000	C14	30	7												
	C15	31	6												
91504-ZM3-003	C6	22	12												
91506-ZM3-000	C6	22	13												
	D3	35	21												
93000															
93500-05025-0A	D6	38	12												
93901-22010	C16	32	11												
93901-34320	C2	18	21												
94000															
94050-05000	C14	30	5												
	C15	31	5												

3

# PART NAME INDEX

F 1

Part name	Address	Page	Ref.	Part name	Address	Page	Ref.	Part name	Address	Page	Ref.
[ A ]				COLLAR, AIR CLEANER .....	C15	31	6	LABEL, WARNING .....	D9	41	10
ARM, EX. VALVE ROCKER .....	C2	18	26	COLLAR, TANK GUARD .....	D2	34	12	LEVER, CONTROL .....	D6	38	1
ARM, IN. VALVE ROCKER .....	C2	18	25	CONTROL ASSY. ....	D6	38	13	LEVER, METERING .....	C11	27	12
ARM, SWING .....	C5	21	7	CORD, STOP SWITCH .....	D4	36	4	LIFTER COMP., EX. VALVE .....	C2	18	28
ARRESTER COMP., SPARK .....	C16	32	3					LIFTER COMP., IN. VALVE .....	C2	18	27
			10	COVER COMP., FAN .....	C8	24	7	[ M ]			
[ B ]				COVER COMP., TOP .....	D7	39	1	MARK .....	D9	41	7
BAR A, HANDLE .....	D10	42	3	COVER, AIR CLEANER .....	C14	30	4	MARK, EMBLEM .....	D8	40	2
BASE COMP., CONTROL .....	D6	38	6						D9	41	9
BEARING, RADIAL BALL, 6001UU .....	C8	24	10	COVER, CYLINDER HEAD .....	C15	31	4	MARK, HONDA .....	D9	41	5
BELT, TIMING .....	C4	20	4	COVER, FAN .....	C1	17	2	MARK, THROTTLE INDICATION .....	D9	41	6
BODY ASSY., AIR PURGE .....	C10	26	6	COVER, PRIMER PUMP .....	C7	23	1	MARK, TYPE .....	D8	40	3
BODY ASSY., PUMP .....	C10	26	5	CRANK COVER SET .....	C11	27	15		D9	41	3
BOLT, 5X53 .....	C12	28	26	CRANKSHAFT COMP. ....	C1	17	1	MUFFLER COMP. ....	C16	32	1
BOLT, 5X59 .....	C12	28	26								2
BOLT, CLUTCH .....	C7	23	3	[ D ]							9
BOLT, FLANGE, 6X22 .....	C8	24	9	DIAPHRAGM ASSY., METERING .....	C9	25	3				
BOLT, SOCKET, 4X14 .....	D4	36	6	DIAPHRAGM, PUMP .....	C9	25	4	[ N ]			
BOLT, SOCKET, 5X10 .....	C16	32	6					NUT, FLANGE, 5MM .....	C14	30	5
	D6	38	10	[ E ]							
BOLT, SOCKET, 5X12 .....	C2	18	18	ELEMENT, AIR CLEANER .....	C14	30	2		C15	31	5
BOLT, SOCKET, 5X16 .....	C6	22	11		C15	31	2	NUT, FLANGE, 7MM .....	D4	36	7
	C12	28	27	[ F ]				NUT, SELF-LOCK, 5MM .....	C16	32	8
	D2	34	10	FILTER, BREATHER .....	C1	17	5	NUT, SELF-LOCK, 6MM .....	D6	38	11
BOLT, SOCKET, 5X20 .....	C2	18	14	FILTER, EXHAUST .....	C16	32	13	NUT, TAPPET ADJUSTING .....	C2	18	19
	C6	22	19	FILTER, FUEL .....	D1	33	6	[ O ]			
	C7	23	5	FILTER, FUEL INLET .....	C11	27	22	OIL SEAL, 10X20X5 .....	C3	19	6
BOLT, SOCKET, 5X30 .....	C2	18	15	FITTING .....	D3	35	16	OIL SEAL, 12X24X5 .....	C3	19	5
	D2	34	9	FLANGE, BAFFLE .....	C16	32	12	O-RING .....	C11	27	14
BOLT, SOCKET, 5X9 .....	D10	42	4	FLYWHEEL COMP. ....	D4	36	3	O-RING, 12.3X2.4 .....	C12	28	29
BOLT, STUD, 2.5X42 .....	C16	32	5	[ G ]				O-RING, 14.8X2.4 .....	C12	28	28
BOLT, STUD, B .....	C6	22	14	GASKET, METERING DIAPHRAGM .....	C9	25	1	[ P ]			
BOLT, TOP COVER .....	D7	39	2	GASKET, PUMP .....	C9	25	2	PACKING, CARBURETOR .....	C12	28	24
[ C ]				GROMMET, FUEL TUBE .....	D1	33	1	PACKING, OIL FILLER CAP .....	C1	17	11
CAP ASSY., FUEL TANK .....	D1	33	5	GROMMET, HEAD COVER .....	C1	17	4	PACKING, SHROUD .....	C13	29	33
	D2	34	15	GUARD, TANK .....	D1	33	4	PIN, LOCK, 6MM .....	C16	32	14
CAP ASSY., OIL FILLER .....	C1	17	10	GUIDE COMP., AIR EX. ....	C16	32	4	PIN, METERING LEVER .....	C10	26	11
CARBURETOR ASSY. ....	C11	27	23	GUIDE, AIR EX. ....	C16	32	4		C11	27	11
	C12	28	23	GUIDE, ROPE .....	C5	21	4	PIN, PISTON .....	C3	19	3
CASE COMP., AIR CLEANER .....	C14	30	3	[ J ]				PIN, SPRING, 4X10 .....	C2	18	22
	C15	31	3	JET .....	C12	28	30	PISTON .....	C3	19	2
CASE, RECOIL STARTER .....	C5	21	2					PLATE ASSY., OIL OUTLET VALVE .....	C1	17	7
	C6	22	15		C13	29	30	PLATE, OIL TRAP .....	C14	30	1
CLAMP, TUBE .....	C2	18	23	[ K ]					C15	31	1
			24	KNOB, RECOIL STARTER .....	C6	22	8	PLUG, SPARK .....	C1	17	13
CLIP, HIGH TENSION CORD .....	D6	38	8	[ L ]				PULLEY COMP., CAMSHAFT .....	C4	20	3
CLIP, TUBE .....	D2	34	11	LABEL, E-SPEC .....	D8	40	1	PULLEY, RECOIL STARTER .....	C5	21	6
CLUTCH ASSY. ....	C7	23	2		D9	41	4	PUMP, PRIMER .....	C11	27	21
COIL ASSY., IGNITION .....	D4	36	1								
	D5	37	9								
COLLAR .....	C6	22	12								
COLLAR A, HEAD COVER .....	C6	22	13								
	D3	35	21								
COLLAR, AIR CLEANER .....	C14	30	7								



# PART NAME INDEX

F 2

Part name	Address	Page	Ref.	Part name	Address	Page	Ref.	Part name	Address	Page	Ref.
[ R ]				[ W ]							
REEL, RECOIL STARTER .....	C5	21	3	WASHER .....	C11	27	20				
RETAINER, VALVE SPRING .....	C4	20	8		C13	29	31				
RING SET, PISTON .....	C3	19	1	WASHER, CLUTCH .....	C7	23	4				
RING, RETAINING .....	C11	27	13	WASHER, CONTROL LEVER .....	D6	38	5				
ROD, THROTTLE .....	D6	38	7	WASHER, WAVE .....	C8	24	6				
ROLLER, 4X29.8 .....	C4	20	2	WRENCH, HEX., 4MM .....	D10	42	2				
ROPE, RECOIL STARTER .....	C6	22	9	WRENCH, SPARK PLUG .....	D10	42	1				
RUBBER, TANK MOUNTING .....	D1	33	3								
[ S ]											
SCREEN, INLET .....	C10	26	7								
SCREW, METERING LEVER PIN .....	C10	26	10								
SCREW, PAN, 4X8 .....	C2	18	16								
SCREW, PAN, 5X25 .....	D6	38	12								
SCREW, PUMP COVER .....	C11	27	18								
SCREW, SETTING .....	C6	22	10								
SCREW, TAPPET ADJUSTING .....	C2	18	17								
SCREW, TAPPING, 3X6 .....	C16	32	11								
SCREW, TAPPING, 4X12 .....	C2	18	21								
SCREW, TAPPING, 4X6 .....	C16	32	7								
SCREW, THROTTLE COLLAR .....	C11	27	17								
SEAL, HEAD COVER .....	C1	17	3								
SEAL, VALVE STEM .....	C4	20	1								
SHAFT COMP., P.T.O. ....	C8	24	8								
SHROUD .....	C12	28	25								
SPACER, CONTROL LEVER .....	D6	38	4								
SPACER, SHROUD .....	C13	29	34								
SPRING, CONTROL ADJUSTING .....	D6	38	2								
SPRING, LEVER .....	D6	38	3								
SPRING, METERING LEVER .....	C10	26	9								
SPRING, PUMP .....	C11	27	19								
SPRING, RECOIL STARTER .....	C5	21	5								
SPRING, VALVE .....	C4	20	7								
STARTER ASSY., RECOIL .....	C5	21	1								
SWITCH ASSY., ENGINE STOP .....	D6	38	9								
SWIVEL .....	C11	27	16								
[ T ]											
TANK, FUEL .....	D1	33	2								
	D2	34	13								
TIE, CABLE .....	D4	36	5								
TUBE A, FUEL .....	D3	35	19								
TUBE, BREATHER .....	C1	17	12								
TUBE, CORRUGATE .....	D4	36	2								
TUBE, FUEL RETURN .....	D2	34	8								
	D3	35	18								
TUBE, FUEL TANK .....	D2	34	7								
	D3	35	17								
TUBE, OIL .....	C1	17	6								
[ V ]											
VALVE, EX. ....	C4	20	6								
VALVE, INLET NEEDLE .....	C10	26	8								
VALVE, IN. ....	C4	20	5								



---

**1**

**FOREWORD INDEX**

---

**2**

**ENGINE GROUP**

---

**3**

**PART NUMBER INDEX**

---

**4**

**PART NAME INDEX**

---

**HONDA**  
The Power of Dreams